



Optical Sensor Product Data Sheet LTR-501ALS-01

Spec No.: DS86-2012-0006

Effective Date: 07/09/2014

Revision: A

LITE-ON DCC

RELEASE

BNS-OD-FC001/A4

LTR-501ALS-01

2-in-1 Digital Light Sensor and Proximity Sensor

Technical Data Sheet

(Preliminary Specification)

SPEC NO: _____

CREATED: 6th May 2011

REV. NO: 1.1

Revision Table

Version	Change Description	Issue Date
1.0	As created	06/05/11
1.1	Outline Dimensions	13/06/11
	Functional Block Diagram	
	Application Circuit: Change SEL pin to NC pin	
	IO Pins Configuration Table	
	Active Supply Current	
	Power Down Sequence for VDD	
	ALS_CONTR Register: ALS Gain	
	PS_CONTR Register: PS Gain	
	ALS Measurement Repeat Rate: Default setting change to 500ms	
	INTERRUPT Register: Output Mode	
	PS_THRES: Change in default value	

1. Description

The LTR-501ALS-01 is an integrated I²C digital light sensor [ALS] and proximity sensor [PS] with built-in LED driver, in a miniature chipLED lead-free surface mount package. This device converts light intensity to a digital output signal capable of direct I²C interface. It provides a linear response over a wide dynamic range from 0.01 lux to 64k lux and is well suited to applications under high ambient brightness. With built-in proximity sensor, LTR-501ALS-01 offers the feature to detect object at a user configurable distance up to 12cm.

The device supports an interrupt feature that removes the need to poll the sensor for a reading which improves system efficiency. The device also supports several features that help to minimize the occurrence of false triggering. This CMOS design and factory-set one time trimming capability ensure minimal device-to-device variations for ease of manufacturability to the end customers.

2. Features

- I²C interface (Fast Mode @ 400kbit/s)
- Ultra-small ChipLED package
- Built-in temperature compensation circuit
- Low active power consumption with standby mode
- Supply voltage range from 2.4V to 3.6V capable of 1.7V logic voltage
- Operating temperature range from -30°C to +70°C
- RoHS and Halogen free compliant
- Light Sensor
 - Close to human eye spectral response
 - Immunity to IR / UV Light Source
 - Automatically rejects 50 / 60 Hz lightings flicker
 - Full dynamic range from 2 lux to 64k lux
 - High resolution range from 0.01 lux to 320 lux
 - 16-bit effective resolution
- Proximity Sensor
 - Built-in LED driver, emitter and detector
 - Programmable LED drive settings
 - 11-bit effective resolution
 - High ambient light suppression

3. Applications

To control display backlight and/or object detection in

- Mobile Devices: Mobile phone, PDA
- Computing Devices: Notebook PC, Desktop Monitor
- Consumer Devices: LCD/PDP TV backlight systems, Cameras, Personal Navigation Device, Digital Photo Frame
- Dashboard

4. Ordering Information

Part Number	Packaging Type	Package	Quantity
LTR-501ALS-01	Tape and Reel	8-pin chipled package	2500

5. Outline Dimensions

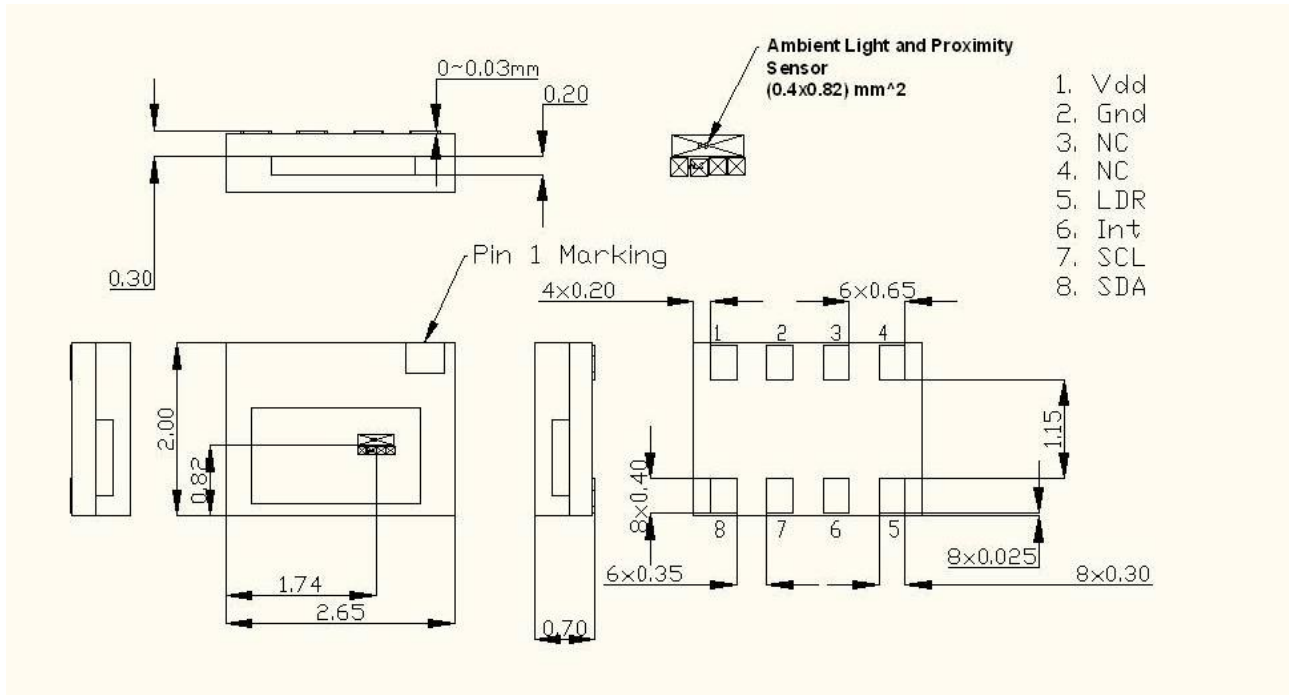

Notes:

1. All dimensions are in millimeters
2. Tolerances: $\pm 0.2\text{mm}$
3. LTC reserves the right to change the drawing till final datasheet release

6. Functional Block Diagram

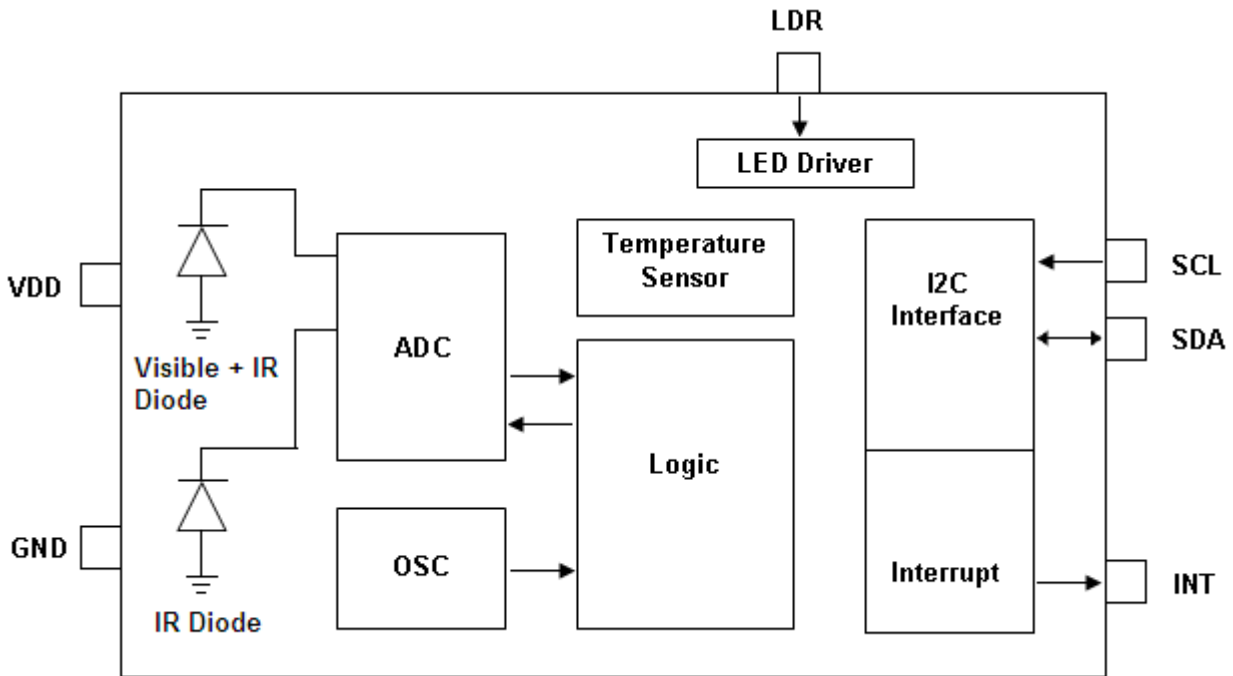

7. Application Circuit

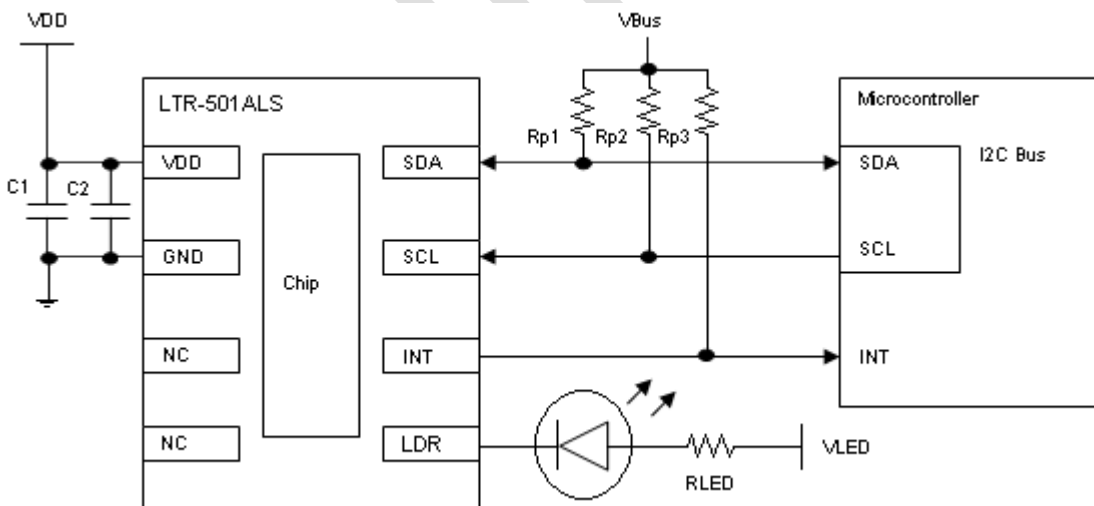

I/O Pins Configuration Table

Pin	I/O Type	Symbol	Description
1		VDD	Supply Voltage
2		GND	Ground
3		NC	No Connect
4		NC	No Connect
5	I	LDR	To connect to LED Cathode.
6	O	INT	Level Interrupt pin. Active LOW for interrupt. This pin is an open drain.
7	I	SCL	I ² C serial clock
8	I/O	SDA	I ² C serial data

Recommended Application Circuit Components

Component	Recommended Value	Condition
Rp1, Rp2, Rp3 [1]	1 k Ω to 10 k Ω	
RLED [2]	TBD	$2.5V \leq VLED \leq 4.35V$
C1	0.1 μ F	
C2	4.7 μ F	

[1] Selection of pull-up resistors value is dependent on bus capacitance values. For more details, please refer to I2C Specifications: http://www.nxp.com/documents/user_manual/UM10204.pdf

[2] IR LED = LTE-C216R-14 or LTE-C248

8. Rating and Specification

Absolute Maximum Ratings at Ta = 25°C

Parameter	Symbol	Rating	Unit
Supply Voltage	VDD	3.8	V
Digital Voltage Range	SCL, SDA, INT	-0.5 to 3.8	V
Digital Output Current	SCL, SDA, INT	-1 to 20	mA
Storage Temperature	T _{stg}	-40 to 85	°C

Note: Exceeding these ratings could cause damage to the sensor. All voltages are with respect to ground. Currents are positive into, negative out of the specified terminal.

Recommended Operating Conditions

Description	Symbol	Min.	Typ.	Max.	Unit	Condition
Supply Voltage	VDD	2.4		3.6	V	
LED Supply Voltage	VLED	2.5		4.35	V	
Interface Bus Power Supply Voltage	V _{IO}	1.7		3.6	V	
Operating Temperature	T _{ope}	-30		70	°C	

Electrical & Optical Specifications

All specifications are at VDD = 3.0V, T_{ope} = 25°C, unless otherwise noted.

Parameter	Min.	Typ.	Max.	Unit	Condition
Active Supply Current		200	300	uA	Active Mode, T _{ope} = 25°C
Standby Current			5	uA	Standby / Sleep Mode
Initial Startup Time			600	ms	(Note 1)
Wakeup Time from Standby			10	ms	(Note 1)

Light Sensor

Parameter	Min.	Typ.	Max.	Unit	Condition
Full Scale ADC Count			65535	count	
Dark ADC Count	0		5	count	Ch0, Lux = 0
	0		5	count	Ch1, Lux = 0
ADC Count	TBD	TBD	TBD	count	Ch0
	TBD	TBD	TBD	count	Ch1
Dynamic Range 1	0.01		320	lux	0.005 lux / count
Dynamic Range 2	2		64k	lux	1 lux / count

Proximity Sensor

Parameter	Min.	Typ.	Max.	Unit	Condition
Full Scale ADC Count			2047	count	
Peak Sensitivity		850		nm	
Detection Distance		120		mm	
Ambient Light Suppression			50k	lux	Direct sunlight
LED Pulse Count	1		255	pulses	
LED Pulse Frequency	30k		100k	Hz	Increment of 10k Hz
LED Duty Cycle	25		100	%	Increment of 25%
LED Peak Current		5		mA	LED Peak Current = 000
		10		mA	LED Peak Current = 001
		20		mA	LED Peak Current = 010
		50		mA	LED Peak Current = 011
		100		mA	LED Peak Current = 100/101/110/111
Optical Rise / Fall Time	100			ns	

Notes:

1. Startup Sequence

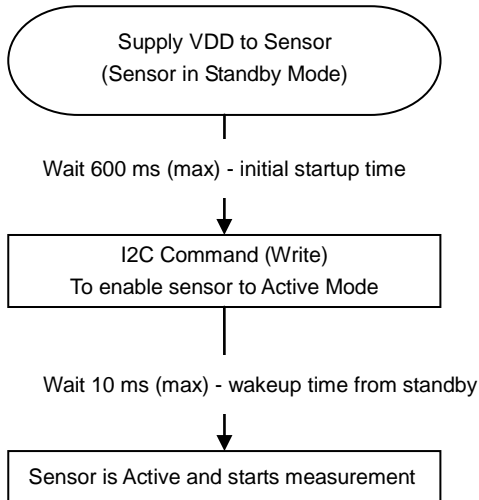

2. Power Down Sequence for VDD

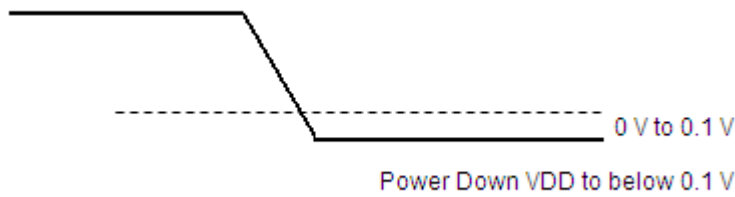

AC Electrical Characteristics

All specifications are at VBus = 1.8V, T_{ope} = 25°C, unless otherwise noted.

Parameter	Symbol	Min.	Max.	Unit
SCL clock frequency	f_{SCL}	1	400	kHz
Bus free time between a STOP and START condition	t_{BUF}	1.3		us
Hold time (repeated) START condition. After this period, the first clock pulse is generated	$t_{HD;STA}$	0.6		us
LOW period of the SCL clock	t_{LOW}	1.3		us
HIGH period of the SCL clock	t_{HIGH}	0.6		us
Set-up time for a repeated START condition	$t_{SU;STA}$	0.6		us
Set-up time for STOP condition	$t_{SU;STO}$	0.6		us
Rise time of both SDA and SCL signals	t_r	30	300	ns
Fall time of both SDA and SCL signals	t_f	30	300	ns
Data hold time	$t_{HD;DAT}$	0.3	0.9	us
Data setup time	$t_{SU;DAT}$	100		ns
Pulse width of spikes which must be suppressed by the input filter	t_{SP}	0	50	ns

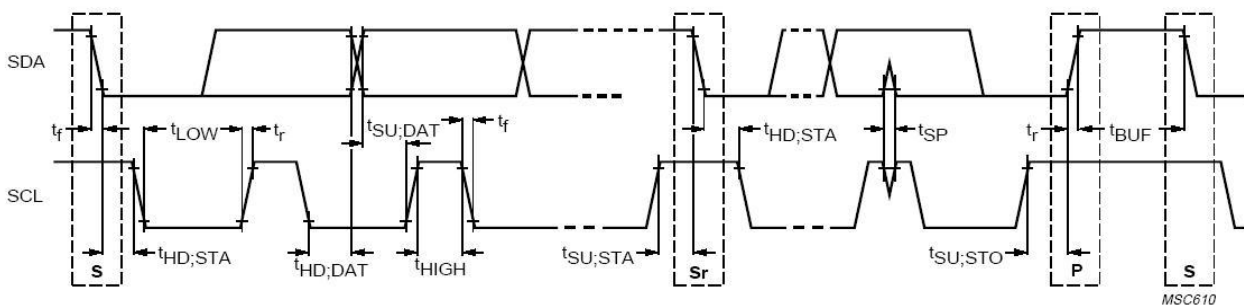

Definition of timing for I²C bus

9. Principles of Operation

I2C Protocols

· I2C Write Protocol (type 1):

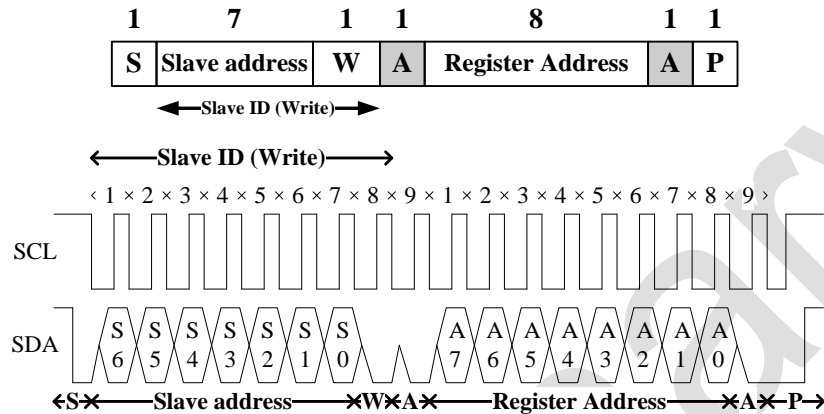

· I2C Write Protocol (type 2):

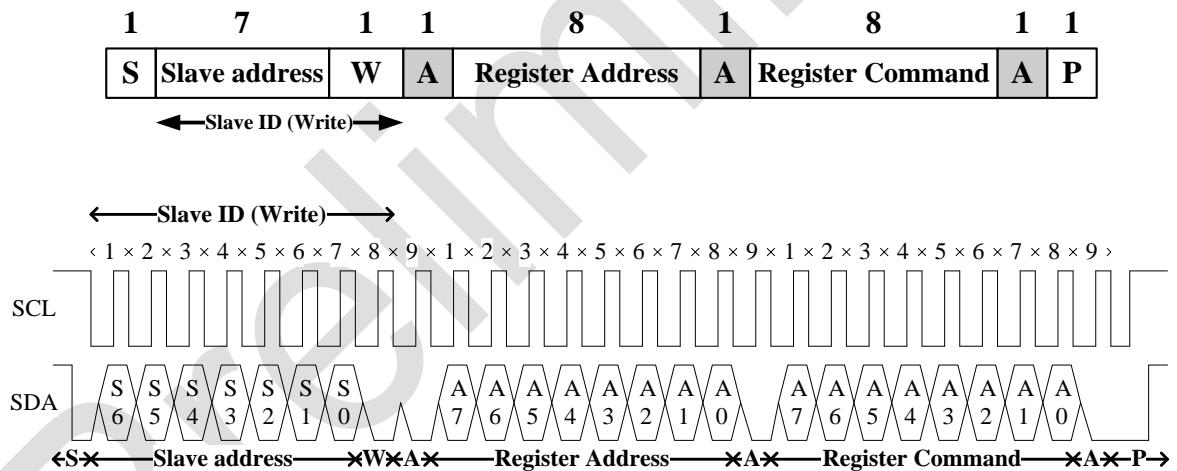

· I2C Read Protocol:

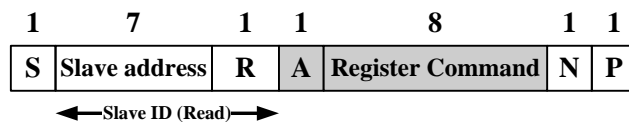

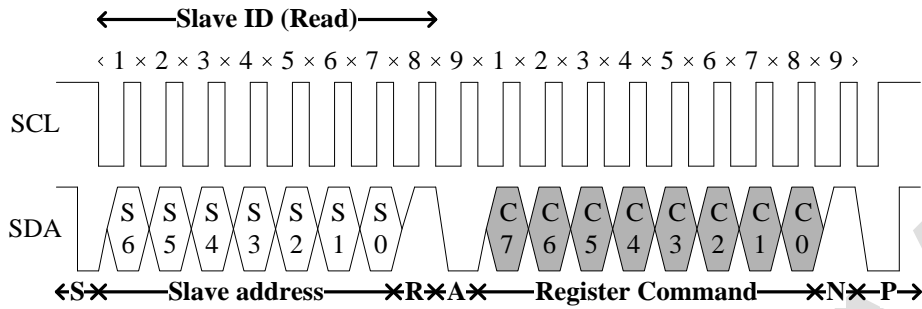

· I2C Read (Combined format) Protocol:

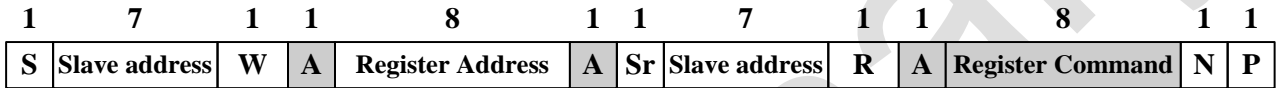

← Slave ID (Write) →

← Slave ID (Read) →

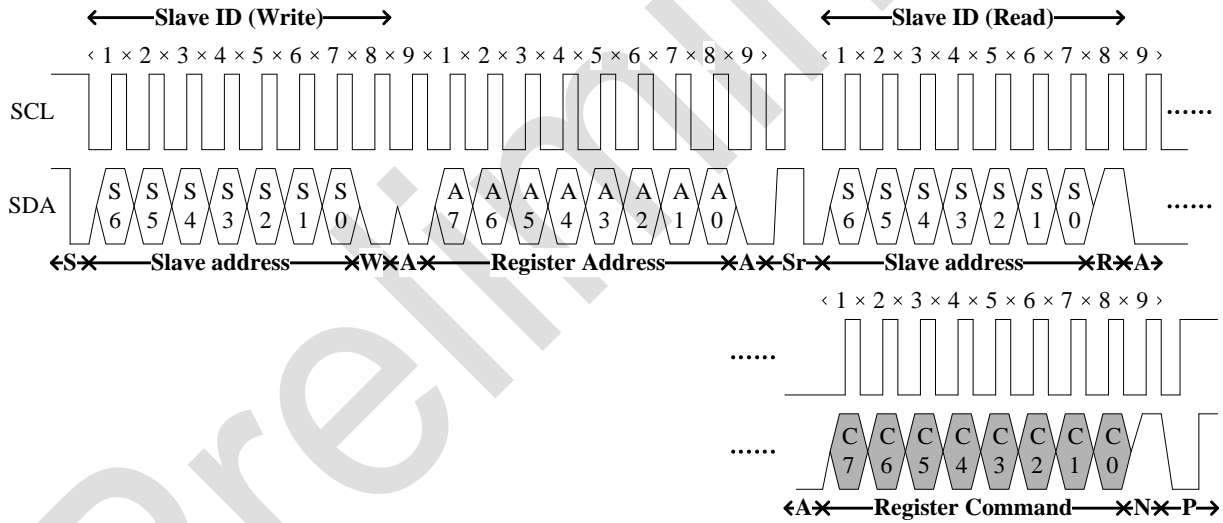

- A** Acknowledge (0 for an ACK)
- S** Start condition
- P** Stop condition
- W** Write (0 for writing)
- Slave-to-master

- N** Non-Acknowledge(1 for an NACK)
- Sr** Repeated Start condition
- R** Read (1 for read)
- Master-to-Slave

I2C Slave Address

The 7 bits slave address for this sensor is 0x23H. A read/write bit should be appended to the slave address by the master device to properly communicate with the sensor.

I2C Slave Address									
Command Type	(0x23H)							W/R	value
	Bit7	Bit6	Bit5	Bit4	Bit3	Bit2	Bit1	Bit0	
Write	0	1	0	0	0	1	1	0	0x46H
Read	0	1	0	0	0	1	1	1	0x47H

Register Set

Addr	R / W	Register Name	Description	Reset Value
0x80	R / W	ALS_CONTR	ALS operation mode control SW reset	0x00
0x81	R / W	PS_CONTR	PS operation mode control	0x00
0x82	R / W	PS_LED	PS LED setting	0x6B
0x83	R / W	PS_N_PULSES	PS number of pulses	0x08
0x84	R / W	PS_MEAS_RATE	PS measurement rate in active mode	0x02
0x85	R / W	ALS_MEAS_RATE	ALS measurement rate in active mode	0x03
0x86	R	PART_ID	Part Number ID and Revision ID	0x80
0x87	R	MANUFAC_ID	Manufacturer ID	0x05
0x88	R	ALS_DATA_CH1_0	ALS measurement CH1 data, lower byte	0x00
0x89	R	ALS_DATA_CH1_1	ALS measurement CH1 data, upper byte	0x00
0x8A	R	ALS_DATA_CH0_0	ALS measurement CH0 data, lower byte	0x00
0x8B	R	ALS_DATA_CH0_1	ALS measurement CH0 data, upper byte	0x00
0x8C	R	ALS_PS_STATUS	ALS and PS new data status	0x00
0x8D	R	PS_DATA_0	PS measurement data, lower byte	0x00
0x8E	R	PS_DATA_1	PS measurement data, upper byte	0x00
0x8F	R / W	INTERRUPT	Interrupt settings	0x08
0x90	R / W	PS_THRES_UP_0	PS interrupt upper threshold, lower byte	0xFF
0x91	R / W	PS_THRES_UP_1	PS interrupt upper threshold, upper byte	0x07
0x92	R / W	PS_THRES_LOW_0	PS interrupt lower threshold, lower byte	0x00
0x93	R / W	PS_THRES_LOW_1	PS interrupt lower threshold, upper byte	0x00
0x97	R / W	ALS_THRES_UP_0	ALS interrupt upper threshold, lower byte	0xFF
0x98	R / W	ALS_THRES_UP_1	ALS interrupt upper threshold, upper byte	0xFF
0x99	R / W	ALS_THRES_LOW_0	ALS interrupt lower threshold, lower byte	0x00
0x9A	R / W	ALS_THRES_LOW_1	ALS interrupt lower threshold, upper byte	0x00
0x9E	R / W	INTERRUPT PERSIST	ALS / PS Interrupt persist setting	0x00

ALS_CONTR Register (0x80)

The ALS_CONTR register controls the ALS operation modes and software (SW) reset for the sensor. The ALS sensor can be set to either standby mode or active mode. At either of these modes, the I²C circuitry is always active. The default mode after power up is standby mode. During standby mode, there is no ALS measurement performed but I²C communication is allowed to enable read/write to all the registers.

0x80	ALS_CONTR (default = 0x00)							
	B7	B6	B5	B4	B3	B2	B1	B0
	Reserved				ALS Gain	SW Reset	ALS Mode	

Field	BITS	Description
Reserved	7:4	Must write as 0
ALS Gain	3	0: Dynamic Range 2 (2 lux to 64k lux) (default) 1: Dynamic Range 1 (0.01 lux to 320 lux)
SW Reset	2	0: Software reset is NOT started (default) 1: Software reset is started, default value after reset is 0
ALS Mode	1:0	00 / 01: Standby Mode (default) 10 / 11: Active Mode

PS_CONTR Register (0x81)

The PS_CONTR register controls the PS operation modes. The PS sensor can be set to either standby mode or active mode. At either of these modes, the I²C circuitry is always active. The default mode after power up is standby mode. During standby mode, there is no PS measurement performed but I²C communication is allowed to enable read/write to all the registers.

0x81	PS_CONTR (default = 0x00)							
	B7	B6	B5	B4	B3	B2	B1	B0
	Reserved				PS Gain		PS Mode	

Field	BITS	Description
Reserved	7:4	Must write as 0
PS Gain	3:2	00: x1 Gain (default) 01: x4 Gain 10: x8 Gain 11: x16 Gain
PS Mode	1:0	00 / 01: Standby Mode (default) 10 / 11: Active Mode

PS_LED Register (0x82)

The PS_LED register controls the LED pulse modulation frequency, LED current duty cycle and LED peak current.

0x82	PS_LED (default = 0x6B)							
	B7	B6	B5	B4	B3	B2	B1	B0
	LED Pulse Frequency			LED Duty Cycle		LED Peak Current		

Field	BITS	Description
LED Pulse Frequency	7:5	000: 30k Hz 001: 40k Hz 010: 50k Hz 011: 60k Hz (default) 100: 70k Hz 101: 80k Hz 110: 90k Hz 111: 100k Hz
LED Duty Cycle	4:3	00: 25% 01: 50% (default) 10: 75% 11: 100%
LED Peak Current	2:0	000: 5mA

	001: 10mA 010: 20mA 011: 50mA (default) Others: 100mA
--	--

PS_N_Pulses Register (0x83)

The PS_N_Pulses register controls the number of LED pulses to be emitted.

0x83	PS_N_Pulses (default = 0x08)							
	B7	B6	B5	B4	B3	B2	B1	B0
	<i>LED Pulse Count</i>							

Field	BITS	Description
LED Pulse Count	7:0	0000 0000: Number of pulses = 0
		0000 0001: Number of pulses = 1
		0000 0010: Number of pulses = 2
		...
		0000 1000: Number of pulses = 8 (default)
		...
		1111 1110: Number of pulses = 254
		1111 1111: Number of pulses = 255

PS_MEAS_RATE Register (0x84)

The PS_MEAS_RATE register controls the timing of the periodic measurements of the PS in active mode. PS Measurement Repeat Rate is the interval between PS_DATA registers update.

0x84	PS_MEAS_RATE (default = 0x02)							
	B7	B6	B5	B4	B3	B2	B1	B0
	<i>Reserved</i>				<i>PS Measurement Repeat Rate</i>			

Field	BITS	Description
Reserved	7:4	Must write as 0
PS Measurement Repeat Rate	3:0	0000: 50ms 0001: 70ms 0010: 100ms (default) 0011: 200ms 0100: 500ms 0101: 1000ms 0110 / 0111: 2000ms 1XXX: Reserved

ALS_MEAS_RATE Register (0x85)

The ALS_MEAS_RATE register controls the integration time and timing of the periodic measurement of the ALS in active mode. ALS Measurement Repeat Rate is the interval between ALS_DATA registers update. ALS Integration Time is the measurement time for each ALS cycle.

ALS Integration Time must be set to be equal or smaller than the ALS Measurement Repeat Rate. If ALS Integration Time is set to be bigger than ALS Measurement Repeat Rate, it will be automatically reset to be equal to ALS Measurement Repeat Rate by the IC internally.

0x85	ALS_MEAS_RATE (default = 0x03)							
	B7	B6	B5	B4	B3	B2	B1	B0
	<i>Reserved</i>			<i>ALS Integration Time</i>		<i>ALS Measurement Repeat Rate</i>		

Field	BITS	Description
Reserved	7:5	Must write as 0
ALS Integration Time	4:3	00: 100ms (default) 01: 50ms (can only be used in Dynamic Range 2, effective resolution is 15-bit @ 2 lux / count) 10: 200ms (can only be used in Dynamic Range 1) 11: 400ms (can only be used in Dynamic Range 1)

ALS Measurement Repeat Rate	2:0	000: 50ms 001: 100ms 010: 200ms 011: 500ms (default) 100: 1000ms 101 / 110 / 111: 2000ms
-----------------------------	-----	---

PART_ID Register (0x86) (Read Only)

The PART_ID register defines the part number and revision identification of the sensor.

0x86	PART_ID (default = 0x80)							
	B7	B6	B5	B4	B3	B2	B1	B0
	<i>Part Number ID</i>				<i>Revision ID</i>			

Field	BITS	Description
Part Number ID	7:4	0x08H
Revision ID	3:0	0x00H

MANUFAC_ID Register (0x87) (Read Only)

The MANUFAC_ID register defines the manufacturer identification of the sensor.

0x87	MANUFAC_ID (default = 0x05)							
	B7	B6	B5	B4	B3	B2	B1	B0
	<i>Manufacturer ID</i>							

Field	BITS	Description
Manufacturer ID	7:0	0x05H

ALS_DATA_CH1 Register (0x88 / 0x89) (Read Only)

The ALS ADC channel 1 data are expressed as a 16-bit data spread over two registers. The ALS_DATA_CH1_0 and ALS_DATA_CH1_1 registers provide the lower and upper byte respectively. When the I²C read operation starts, both the registers are locked until the I²C read operation is completed. This will ensure that the data in the registers is from the same measurement even if an additional integration cycle ends during the read operation. New measurement data is stored into temporary registers and the ALS_DATA registers are updated as soon as there is no on-going I²C read operation.

0x88	ALS_DATA_CH1_0 (default = 0x00)							
	B7	B6	B5	B4	B3	B2	B1	B0
	<i>ALS Data Ch1 Low</i>							

0x89	ALS_DATA_CH1_1 (default = 0x00)							
	B7	B6	B5	B4	B3	B2	B1	B0
	<i>ALS Data Ch1 High</i>							

Field	Addr	BITS	Description
ALS Data Ch1 Low	0x88	7:0	ALS ADC channel 1 lower byte data
ALS Data Ch1 High	0x89	7:0	ALS ADC channel 1 upper byte data

ALS_DATA_CH0 Register (0x8A / 0x8B) (Read Only)

The ALS ADC channel data 0 are expressed as a 16-bit data spread over two registers. The ALS_DATA_CH0_0 and ALS_DATA_CH0_1 registers provide the lower and upper byte respectively. When the I²C read operation starts, both the registers are locked until the I²C read operation is completed. This will ensure that the data in the registers is from the same measurement even if an additional integration cycle ends during the read operation. New measurement data is stored into temporary registers and the ALS_DATA registers are updated as soon as there is no on-going I²C read operation.

0x8A	ALS_DATA_CH0_0 (default = 0x00)							
	B7	B6	B5	B4	B3	B2	B1	B0
	<i>ALS Data Ch0 Low</i>							

0x8B	ALS_DATA_CH0_1 (default = 0x00)							
	B7	B6	B5	B4	B3	B2	B1	B0
	<i>ALS Data Ch0 High</i>							

Field	Addr	BITS	Description
ALS Data Ch0 Low	0x8A	7:0	ALS ADC channel 0 lower byte data
ALS Data Ch0 High	0x8B	7:0	ALS ADC channel 0 upper byte data

ALS_PS_STATUS Register (0x8C) (Read Only)

The ALS_PS_STATUS register stores the information about interrupt status and ALS and PS data status. New data means data has not been read yet. When the measurement is completed and data is written to the data register, the data status bit will be set to logic 1. When the data register is read, the data status bit will be set to logic 0.

Interrupt status determines if the ALS and PS interrupt criteria are met. It will check if the ALS or PS measurement data is outside of the range defined by the upper and lower threshold limits.

0x8C	ALS_PS_STATUS (default = 0x00)							
	B7	B6	B5	B4	B3	B2	B1	B0
	<i>Reserved</i>			<i>ALS Gain</i>	<i>ALS Interrupt Status</i>	<i>ALS Data Status</i>	<i>PS Interrupt Status</i>	<i>PS Data Status</i>

Field	BITS	Description
Reserved	7:5	Do not care

ALS Gain	4	0: ALS measurement data is in dynamic range 2 (2 to 64k lux) 1: ALS measurement data is in dynamic range 1 (0.01 to 320 lux)
ALS Interrupt Status	3	0: ALS interrupt is clear or not yet triggered 1: ALS interrupt is triggered
ALS Data Status	2	0: ALS measurement data is old data (Data has been read) 1: ALS measurement data is new data (Data has not been read)
PS Interrupt Status	1	0: PS interrupt is clear or not yet triggered 1: PS interrupt is triggered
PS Data Status	0	0: PS measurement data is old data (Data has been read) 1: PS measurement data is new data (Data has not been read)

PS_DATA_0 Register (0x8D / 0x8E) (Read Only)

The PS ADC channel data are expressed as a 11-bit data spread over two registers. The PS_DATA_0 and PS_DATA_1 registers provide the lower and upper byte respectively. When the I²C read operation starts, both the registers are locked until the I²C read operation is completed. This will ensure that the data in the registers is from the same measurement even if an additional integration cycle ends during the read operation. New measurement data is stored into temporary registers and the PS_DATA registers are updated as soon as there is no on-going I²C read operation.

0x8D	PS_DATA_0 (default = 0x00)							
	B7	B6	B5	B4	B3	B2	B1	B0
	<i>PS Data Low</i>							

0x8E	PS_DATA_1 (default = 0x00)							
	B7	B6	B5	B4	B3	B2	B1	B0
	<i>Reserved</i>					<i>PS Data High</i>		

Field	Addr	BITS	Description
PS Data Low	0x8D	7:0	PS ADC lower byte data

Reserved	0x8E	7:3	Do not care
PS Data High	0x8E	2:0	PS ADC upper byte data

INTERRUPT Register (0x8F)

The INTERRUPT register controls the operation of the interrupt pin and functions. When the Interrupt Mode is set to 00, the INT output pin 2 is inactive / disabled and will not trigger any interrupt. However at this condition, the ALS_PS_STATUS register will still be updated.

0x8F	INTERRUPT (default = 0x08)							
	B7	B6	B5	B4	B3	B2	B1	B0
	Reserved				Output Mode	Interrupt Polarity	Interrupt Mode	

Field	BITS	Description
Reserved	7:4	Must write as 0
Output Mode	3	0: INT output pin 2 is latched and keep in triggered state until INTERRUPT Register is read 1: INT output pin 2 is updated after every measurement (default)
Interrupt Polarity	2	0: INT output pin 2 is considered active when it is a logic 0 (default) 1: INT output pin 2 is considered active when it is a logic 1
Interrupt Mode	1:0	00: INT output pin 2 is inactive / high impedance state (default) 01: Only PS measurement can trigger interrupt 10: Only ALS measurement can trigger interrupt 11: Both ALS and PS measurement can trigger interrupt

PS_THRES Register (0x90 / 0x91 / 0x92 / 0x93)

The PS_THRES_UP and PS_THRES_LOW registers determines the upper and lower limit of the interrupt threshold value respectively. These two values form a range and the interrupt function compares if the measurement value in PS_DATA registers is inside or outside the range. The interrupt function is active if the measurement data is outside the range defined by the upper and lower limits. The data format for PS_THRES must be the same as PS_DATA registers.

0x90	PS_THRES_UP_0 (default = 0xFF)							
	B7	B6	B5	B4	B3	B2	B1	B0
	<i>PS Upper Threshold Low</i>							

0x91	PS_THRES_UP_1 (default = 0x07)							
	B7	B6	B5	B4	B3	B2	B1	B0
	<i>Reserved</i>					<i>PS Upper Threshold High</i>		

0x92	PS_THRES_LOW_0 (default = 0x00)							
	B7	B6	B5	B4	B3	B2	B1	B0
	<i>PS Lower Threshold Low</i>							

0x93	PS_THRES_LOW_1 (default = 0x00)							
	B7	B6	B5	B4	B3	B2	B1	B0
	<i>Reserved</i>					<i>PS Lower Threshold High</i>		

Field	Addr	BITS	Description
PS Upper Threshold Low	0x90	7:0	PS upper threshold lower byte
Reserved	0x91	7:3	Must write as 0
PS Upper Threshold High	0x91	2:0	PS upper threshold upper byte
PS Lower Threshold Low	0x92	7:0	PS lower threshold lower byte
Reserved	0x93	7:3	Must write as 0

PS Lower Threshold High	0x93	2:0	PS lower threshold upper byte
-------------------------	------	-----	-------------------------------

ALS_THRES Register (0x97 / 0x98 / 0x99 / 0x9A)

The ALS_THRES_UP and ALS_THRES_LOW registers determines the upper and lower limit of the interrupt threshold value respectively. These two values form a range and the interrupt function compares if the measurement value in ALS_DATA registers is inside or outside the range. The interrupt function is active if the measurement data is outside the range defined by the upper and lower limits. The data format for ALS_THRES must be the same as ALS_DATA registers.

0x97	ALS_THRES_UP_0 (default = 0xFF)							
	B7	B6	B5	B4	B3	B2	B1	B0
	<i>ALS Upper Threshold Low</i>							

0x98	ALS_THRES_UP_1 (default = 0xFF)							
	B7	B6	B5	B4	B3	B2	B1	B0
	<i>ALS Upper Threshold High</i>							

0x99	ALS_THRES_LOW_0 (default = 0x00)							
	B7	B6	B5	B4	B3	B2	B1	B0
	<i>ALS Lower Threshold Low</i>							

0x9A	ALS_THRES_LOW_1 (default = 0x00)							
	B7	B6	B5	B4	B3	B2	B1	B0
	<i>ALS Lower Threshold High</i>							

This preliminary data is provided to assist you in the evaluation of product(s) currently under development. Until LTC releases this product for general sales, LTC reserves the right to alter prices, specifications, features, capabilities, functions, release dates, and remove availability of the product(s) at anytime

Field	Addr	BITS	Description
ALS Upper Threshold Low	0x97	7:0	ALS upper threshold lower byte
ALS Upper Threshold High	0x98	7:0	ALS upper threshold upper byte
ALS Lower Threshold Low	0x99	7:0	ALS lower threshold lower byte
ALS Lower Threshold High	0x9A	7:0	ALS lower threshold upper byte

INTERRUPT PERSIST Register (0x9E)

The INTERRUPT PERSIST register controls the N number of times the measurement data is outside the range defined by the upper and lower threshold limits before asserting the INT output pin 2.

0x9E	INTERRUPT PERSIST (default = 0x00)							
	B7	B6	B5	B4	B3	B2	B1	B0
	<i>PS Persist</i>				<i>ALS Persist</i>			

Field	BITS	Description
PS Persist	7:4	0000: Every PS measurement data will generate an interrupt (default) 0001: 1 consecutive PS measurement data outside the range 0010: 2 consecutive PS measurement data outside the range ... 1111: 15 consecutive PS measurement data outside the range
ALS Persist	3:0	0000: Every ALS measurement data will generate an interrupt (default) 0001: 1 consecutive ALS measurement data outside the range 0010: 2 consecutive ALS measurement data outside the range ... 1111: 15 consecutive ALS measurement data outside the range

This preliminary data is provided to assist you in the evaluation of product(s) currently under development. Until LTC releases this product for general sales, LTC reserves the right to alter prices, specifications, features, capabilities, functions, release dates, and remove availability of the product(s) at anytime

10. Recommended Leadfree Reflow Profile

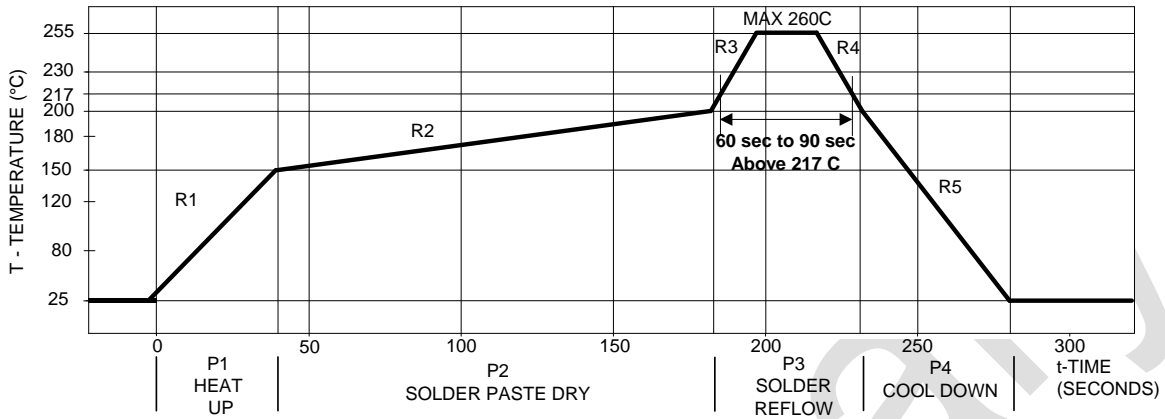

Process Zone	Symbol	ΔT	Maximum $\Delta T/\Delta \text{time}$ or Duration
Heat Up	P1, R1	25°C to 150°C	3°C/s
Solder Paste Dry	P2, R2	150°C to 200°C	100s to 180s
Solder Reflow	P3, R3	200°C to 260°C	3°C/s
	P3, R4	260°C to 200°C	-6°C/s
Cool Down	P4, R5	200°C to 25°C	-6°C/s
Time maintained above liquidus point , 217°C		> 217°C	60s to 90s
Peak Temperature		260°C	-
Time within 5°C of actual Peak Temperature		> 255°C	20s
Time 25°C to Peak Temperature		25°C to 260°C	8mins

It is recommended to perform reflow soldering no more than twice.

11. Moisture Proof Packaging

All LTR-501ALS-01 are shipped in moisture proof package. Once opened, moisture absorption begins. This part is compliant to JEDEC J-STD-033A Level 3.

Time from Unsealing to Soldering

After removal from the moisture barrier bag, the parts should be stored at the recommended storage conditions and soldered within seven days. When the moisture barrier bag is opened and the parts are exposed to the recommended storage conditions for more than seven days, the parts must be baked before reflow to prevent damage to the parts.

Recommended Storage Conditions

Storage Temperature	10°C to 30°C
Relative Humidity	Below 60% RH

Baking Conditions

Package	Temperature	Time
In Reels	60°C	48 hours
In Bulk	100°C	4 hours

Baking should only be done once.

12. Recommended Land Pattern and Metal Stencil Aperture

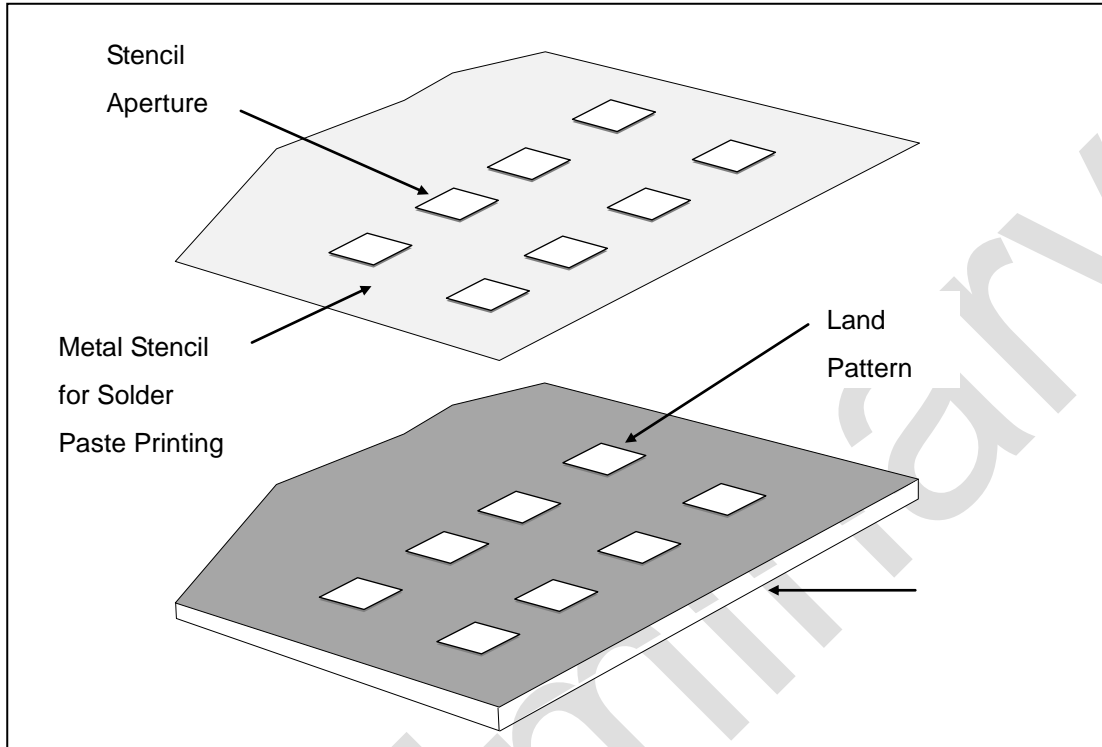

Recommended Land Pattern

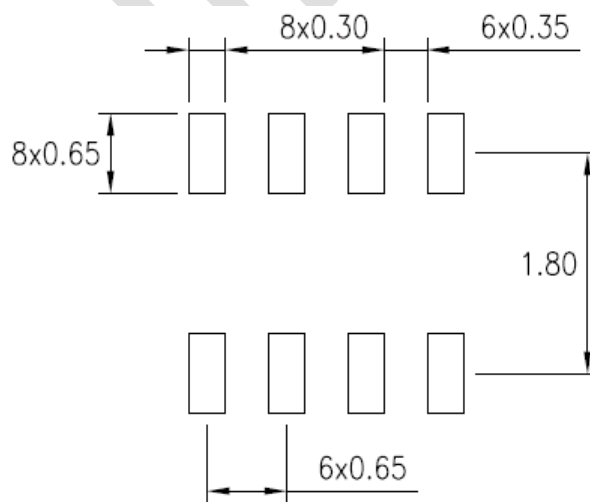

Note:

1. All dimensions are in millimeters

Recommended Metal Stencil Aperture

It is recommended that the metal stencil used for solder paste printing has a thickness (t) of 0.11 mm (0.004 inches / 4 mils) or 0.127 mm (0.005 inches / 5 mils).

The stencil aperture opening is recommended to be 0.3 mm x 0.65 mm which has the same dimension as the land pattern. This is to ensure adequate printed solder paste volume and yet no shorting.

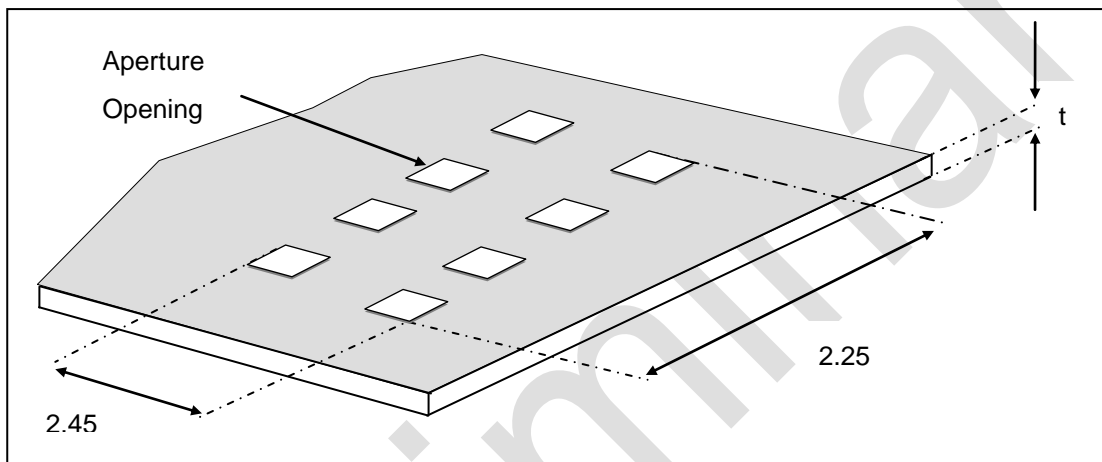

Note:

1. All dimensions are in millimeters

13. Package Dimension for Tape and Reel

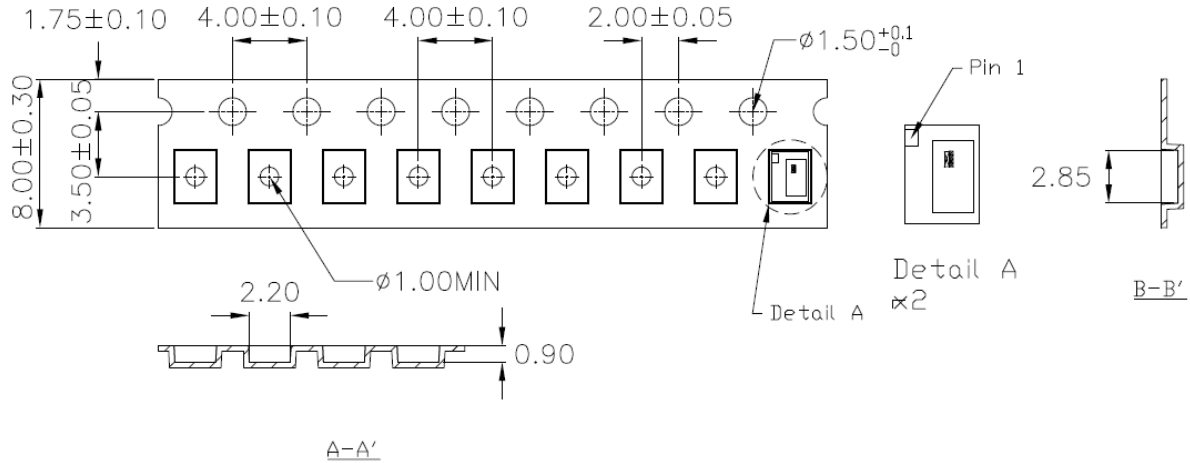

Note:

1. All dimensions are in millimeters

Package Dimension of Reel

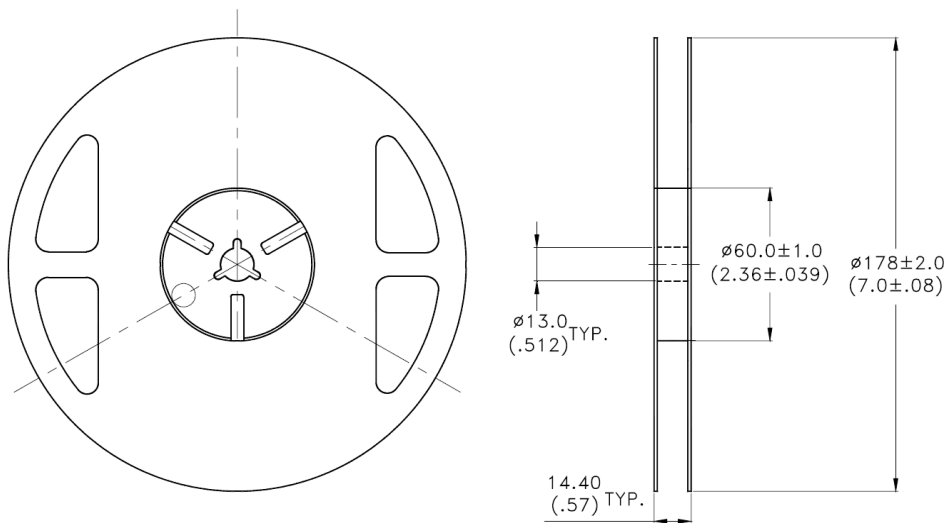

Notes:

1. All dimensions are in millimeters (inches)
2. Empty component pockets sealed with top cover tape
3. 7 inch reel - 2500 pieces per reel
4. In accordance with ANSI/EIA 481-1-A-1994 specifications