

A decorative graphic on the left side of the cover, consisting of a grid of blue diamonds of various shades (light blue, medium blue, dark blue) arranged in a pattern that recedes into the distance.

ADS1000 Series

DIGITAL STORAGE OSCILLOSCOPE

User's Manual

Version No.: V1.0

Announcement

The content in this manual could be changed without prior notice.

NANJING GLARUN-ATTEN TECHNOLOGY CO. LTD provides no warranty of any kind to this manual and assumes no liability or responsibility for any mistakes possibly contained in the manual or any occasional or subsequent loss caused by using this manual.

Copyright

© 2012 NANJING GLARUN-ATTEN TECHNOLOGY CO. LTD All Rights Reserved.

Trademark Logo



is the registered trademark of NANJING GLARUN-ATTEN TECHNOLOGY CO. LTD.

Declaration

- The products of the company are under protection of the People's Republic of China Patent that has been approved or is pending.
 - The company reserves the right to change the specifications and prices.
 - Limited by the People's Republic of China and international copyright laws, any entities and individual cannot copy or spread the content of this manual (including electronic manuals) as well as translate the content into other languages without authorization of NANJING GLARUN-ATTEN TECHNOLOGY CO. LTD.
-

Security terms and characters

Terms in this manual. The following terms may appear in this manual:



Warning

The warning announcement points out the operation or condition that may endanger the operators.



Notice

The notice announcement points out the operation or condition that may cause damage to the product or other properties.

Terms on the product. The following terms may appear on the product:

Danger It represents that harms may be caused to you at once if you perform the operation.

Warning It represents that latent harms may be caused to you if you perform the operation.

Notice It represents the damage possibly caused to the product or other properties if you perform the operation.

Characters on the product. The following characters may appear on the product:



Notice
Please read
the manual



Protective
ground terminal



Measuring
ground terminal



Chassis
ground terminal

Introduction to GA1000 series of digital storage oscilloscope

GA1000 oscilloscope has a real-time sampling rate as high as 2GSa/s, therefore it is capable of catching complex and quickly changing signals. It supports storage of USB equipment, and is capable of updating and upgrading the system software by a USB flash disc.

GA1000 series of digital storage oscilloscope is small in size and flexible to operate. It adopts a TFT LCD and a pop-up menu for display, and can remarkably improve the working efficiency by its ease of use.

GA1000 series of oscilloscope has excellent performance, various functions and competitive cost to performance ratio.

Model	Bandwidth	Sampling Rate
GA1102CAL	100MHz	1GSa/s
GA1202CAL	200MHz	2GSa/s
GA1302CAL	300MHz	2GSa/s

Characteristics:

- ◆ The oscilloscope has a totally new ultrathin appearance design, and is small in size and more portable
- ◆ A 7-inch widescreen color TFT LCD displays clear, crisp and more stable waveform display
- ◆ Storage/ Memory depth: single channel: 40Kpts; double channels: 20Kpts
- ◆ Various trigger functions: Edge, Pulse, Video, Slope and Alternation
- ◆ Unique digital filtering and waveform recording functions
- ◆ Pass/Fail function

- ◆ 32 kinds of automatic measurement and manual cursor tracking measurement functions
- ◆ Two groups of reference waveforms, 16 groups of common waveforms, 20 groups of internal storage/output; support waveform setting, external storage and output of CSV and bitmap file by USB flash disc (CSV and bitmaps cannot be output from USB flash disc)
- ◆ Adjustable waveform brightness and screen grid brightness
- ◆ The pop-up menu display mode realizes more flexible and more natural for users' operations
- ◆ Various kinds of language interface display, Chinese and English
- ◆ On-line help system
- ◆ Shortcut key PRINT, support print screen
- ◆ Standard configuration interfaces: USB Host, USB Device, RS-232
- ◆ USB Host: support storage of USB flash disc and upgrading of USB flash disc system software
- ◆ USB Device: support PC connection for remote communication;

GA1000 series of digital storage oscilloscope accessories:

- ◆ User's manual
- ◆ Product warranty card
- ◆ Certificate of approval
- ◆ 1: 1/10: 1 probes(2 PCS ea)
- ◆ Power cord satisfying the standard of the user's country
- ◆ USB cable
- ◆ Optical disc (containing PC software GAScope1.0)

Content Summary

The manual introduces related information about the operation of this series of digital oscilloscope and comprises the following chapters and sections:

- ◆ Chapter "Introduction" introduces the front panel, the user interface, the function check and the probe compensation of the oscilloscope.
- ◆ Chapter "Function Introduction and Operation" systematically introduces the function and operation of the oscilloscope in detail.
- ◆ Chapter "Application Example" includes many measure examples offered for reference for users.
- ◆ Chapter "System Prompt and Fault Recovery" introduces the system prompts and lists some simple faults and solutions so that the users are capable to rectify simple faults.
- ◆ Chapter "Service and Support" introduces the warranty and technical support of this series of product.
- ◆ Chapter "Appendix A: Technical Specification" introduces the technical specification of this series of oscilloscope in detail.
- ◆ Chapter "Appendix B: Default Setting" lists related factory settings.
- ◆ Chapter "Appendix C: Daily Maintenance and Cleaning" introduces the way to maintain the oscilloscope.

2.6.2 Window expansion.....	31
2.7 Triggering system.....	32
2.7.1 Signal source.....	33
2.7.2 Type.....	33
2.7.3 Coupling.....	42
2.7.4 Trigger hold-off.....	43
2.8 Signal acquisition system.....	44
2.9 Display system.....	48
2.9.1 X-Y mode.....	50
2.10 Measurement system.....	52
2.10.1 Scale measurement.....	52
2.10.2 Cursor measurement.....	52
2.10.3 Measurement.....	55
2.11 Storage system.....	62
2.12 Auxiliary system.....	68
2.12.1 System status.....	70
2.12.2 Language selection.....	70
2.12.3 Self correction.....	71
2.12.4 Self test.....	71
2.12.5 Firmware upgrading.....	73
2.12.6 Test passed.....	73
2.12.7 Waveform recording.....	77
2.12.8 Interface setting.....	79
2.13 Help function.....	80

Chapter 3 Application Examples	81
3.1 Simple Measurement.....	81
3.2 Cursor Measurement.....	83
3.2.1 Measurement of width of spike pulse.....	83
3.2.2 Measurement of amplitude of spike pulse.....	83
3.3 Single signal catching.....	85
3.4 Detailed information of analysis signal.....	86
3.4.1 Noise signal observation.....	86
3.4.2 Separation of signal from noise.....	86
3.5 Application of X-Y function.....	87
3.6 Application of arithmetical operation in communication signal difference analysis.....	89
3.7 Screen capture.....	90
Chapter 4 System prompt and Fault Recovery	91
4.1 System prompt message description.....	91
4.2 Fault treatment.....	93
Chapter 5 Service and Support	95
5.1 Maintain summary.....	95
Chapter 6 Appendix	96
Appendix A: Technical specification.....	96
Appendix B: Default setting.....	101

Appendix C: Daily maintenance and cleaning.....105

Introduction

DIGITAL STORAGE OSCILLOSCOPE

This series of digital storage oscilloscope is a small and light portable instrument that can be measured by a ground voltage as reference.

This chapter introduces how to implement the following tasks:

- Accidence of front panel and user interface
- Implement brief function checks
- Match probe attenuation coefficients
- Implement probe compensation

1.1 Accidence of front panel and the user interface

This section will make you understand the front operation panel of this series of digital oscilloscope at first before use.

The content below simply describes and introduces the front panel and the back part of this series of digital oscilloscope so that you can know this series of digital oscilloscope well within the shortest time.

1.1.1 Front panel

This series of digital oscilloscope has a front panel that is simple but clear in function, and is convenient for a user to finish basic operations. Knobs and functional keys are arranged on the panel. Five grey keys which have been arranged in a row on the left side of a display screen are option keys. The current menu can be provided with different options. The other keys are function keys that can be set in different functional menus or directly obtain specific function application. The knobs can be used for quickly regulating the corresponding setups of the oscilloscope.

Attention: in this specifications, 【 】 represents the keys and knobs of the oscilloscope, and "" represents the menu options displayed in a program interface.

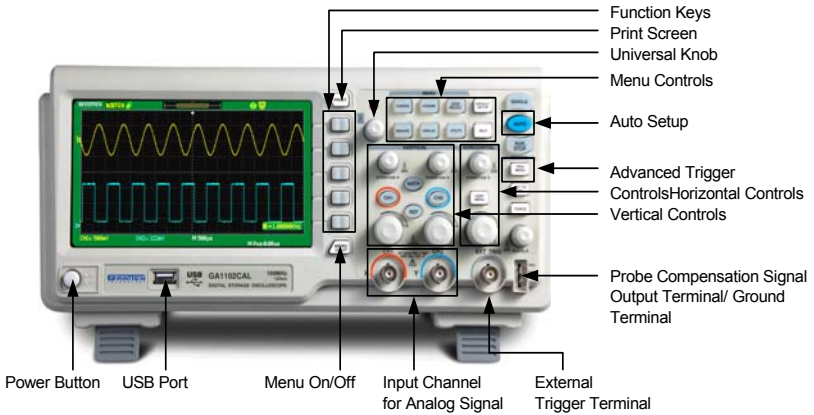

Figure 1-1 Figure of Front Panel controls

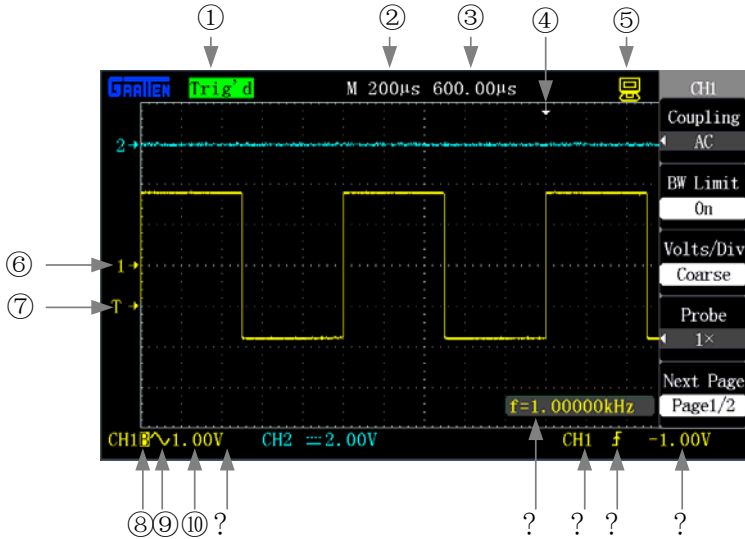

Figure 1-2 Interface display

No.	Details
-----	---------

① Trigger status

Armed: The oscilloscope is acquiring pre-triggering data. All triggers are ignored in this state.

Ready: The oscilloscope has acquired all the pre-triggering data and is ready to accept a trigger.

Trig'd: The oscilloscope has caught a single trigger and acquires the data after triggering.

Stop: The oscilloscope has stopped acquiring waveform data.

Auto: The oscilloscope is at an auto mode and acquires the waveform at a non-triggered state.

Scan: The oscilloscope continuously acquires and displays the waveform at a scan mode.

-
- ② The reading displays the setup of a main time base.
-
- ③ It displays a time reading from the central scale.
-
- ④ The identifier displays the horizontal trigger position.
The horizontal [POSITION] knob is used for regulating the horizontal trigger position
-
- ⑤  It represents the oscilloscope is connected to a computer
-
- ⑥ The identifier displays a zero electrical level standard point of the channel waveform.
The identifier is displayed only when the channel is open
-
- ⑦ The identifier displays a trigger electrical level
-
- ⑧ The identifier displays bandwidth limit of the channel.
-
- ⑨ The identifier displays coupling mode of the channel.
-
- ⑩ The reading displays vertical scale coefficient of the channel.
-
- ⑪ The identifier displays inverse phase of waveform of the channel.
-
- ⑫ The reading displays counting frequency of a frequency meter.
-
- ⑬ It displays a trigger source selected at present.
-
- ⑭ The icon displays a selected trigger type.
-
- ⑮ The reading displays a set trigger electrical level value.
-

1.1.2 Instrument back

This series of digital oscilloscope provides various standard interfaces, as shown in the figure below :



1. Pass/Fail output port: output a Pass/Fail detection pulse
2. RS-232 interface: connect test software or waveform printing (a bit slow)
3. USB Device interface: connect test software or waveform printing (quick)
4. Power input interface: input a three-hole power supply

1.2 Function check

Carry out a quick function check to check whether the oscilloscope works normally according to the following steps:

1. Turn on the power source, and set the default attenuation as 1× according to the probe option [DEFAULT setup].
2. Set a switch on a probe of the oscilloscope as ×1 and connect the probe with a connector CH1BNC of the oscilloscope. Connect a hook-shaped head of the probe to a probe compensation signal connector marked with "1KHz", and clamp a grounding hook marked with "GND" by a grounding clamp, as shown in the figure below:

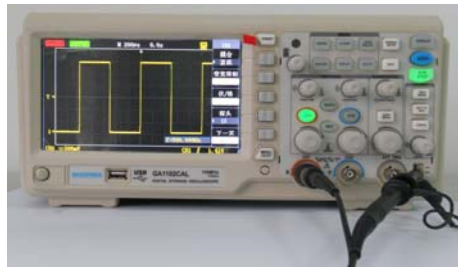

Figure 1-4 Function detection

3. Press [AUTO]. Within few seconds, CH1 displays a square wave of which the frequency is 1kHz and the peak-to-peak voltage value is 3V.

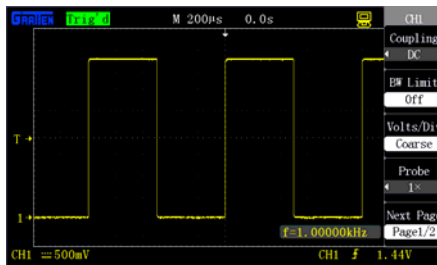

Figure 1-5 Probe compensation signal

4. Connect the probe with channel 2, and CH2 displays the same waveform after [AUTO] is pressed.

1.3 Probe

1.3.1 Probe safety

Check and obey the rated values of the probe parameters before using it.

A protective device surrounding the probe main body can prevent fingers from electric shock.

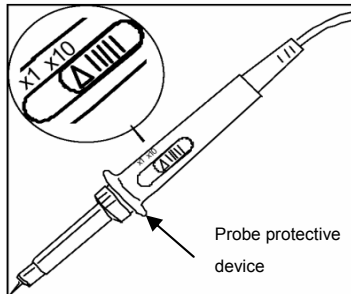

Figure 1-6 Probe

Connect the probe to the oscilloscope and ground the ground terminal before any measurement.

Attention:

- Keep fingers behind the protective curve on the probe main body to prevent electric shock when using the probe.
- Do not contact the metal part on the top of the probe when the probe is connected to a voltage source.
- The signal measured by the oscilloscope uses "ground" as reference voltage, and the ground terminal should be grounded correctly to prevent short circuit.

1.3.2 Probe attenuation setting

The probe has different attenuation coefficients that influence the vertical scale of the signal. The "ATTENUATION" switch on the probe is ensured to be matched with the "PROBE" coefficients in the oscilloscope.

Manually set the probe options, press down the vertical menu key, and then select the "PROBE" option (such as [CH1] → "PROBE").

- Default setup of the probe optical is 1X.
- When the "ATTENUATION" switch is set as $\times 1$, the probe limits the bandwidth of the oscilloscope within 0-10 MHz (different probes have different specifications). Ensure that the switch is set to be $\times 10$ when to use the full bandwidth of the oscilloscope.

1.3.3 Probe compensation

Carry out probe compensation when the probe connect the channel for the first time so as to match the probe with the channel. Under compensation or Over compensation of the probe may cause measurement errors or mistakes.

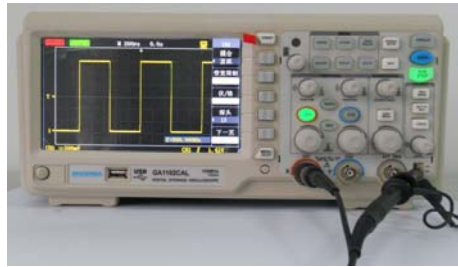

Figure 1-7 Probe compensation connection figure

1. Set the probe coefficient to 10X in channel menu, set the switch on the probe to $\times 10$, and connect the probe of the oscilloscope with channel 1.
2. Connect the end part of the probe to the probe compensation connector "1KHz", clamping the connector "GND" by the ground clamp, turn on the channel displayer, and then press [AUTO] to display the waveform.

3. Check the shape of the displayed waveform.



under compensated



suitable compensated



over compensated

4. If necessary, rotate the adjustable capacitor on the probe handle to realize suitable compensated.

Function Introduction and Operation

DIGITAL STORAGE OSCILLOSCOPE

2

This chapter introduces the functional keys and operations of the front panel of the series of oscilloscope in detail.

For effectively using the oscilloscope, the following functions of the oscilloscope are needed to be known:

- Menu and control keys
- Connector
- Automatic setup
- Default setup
- “Universal” knob
- Vertical system
- Horizontal system
- Triggering system
- Signal acquisition system
- Display system
- Measurement system
- Save system
- Auxiliary system
- On-line help system

2.1 Menu and control keys

As shown in the figure below :



Figure 2-1 Control keys

All the keys are described as follows:

- **[CH1], [CH2]:** display setup menus of channel 1 and channel 2.
- **[MATH]:** display "ARITHMETICAL OPERATION" function menu.
- **[REF]:** display "REFERENCE WAVEFORM" menu.
- **[HORI MENU]:** display "HORIZONTAL" menu.
- **[TRIG MENU]:** display "TRIGGER" control menu.
- **[SET TO 50%]:** set the trigger electric level as midpoint of the signal amplitude.
- **[FORCE]:** It is used for finishing acquisition of the current waveform no matter whether the oscilloscope detects trigger, and it is mainly applied to "NORMAL" and "SINGLE" in the trigger mode.
- **[SAVE/RECALL]:** display the "SAVE/RECALL" menu of setups and waveform.
- **[ACQUIRE]:** display the "ACQUIRE" menu.
- **[MEASURE]:** display the "MEASURE" menu.
- **[CURSORS]:** display the "CURSOR" menu. The [UNIVERSAL] knob can be used for regulating the position of the cursor when the "CURSOR" menu is displayed and the cursor is triggered.

- **[DISPLAY]:** display the "DISPLAY" menu.
- **[UTILITY]:** display "AUXILIARY FUNCTION" menu.
- **[DEFAULT SETUP]:** recall the default factory setup.
- **[HELP]:** enter the on-line help system.
- **[AUTO]:** automatically set the control state of the oscilloscope so as to display suitable waveform.
- **[RUN/STOP]:** continuously acquire waveform or stop acquisition
- **[SINGLE]:** Acquire a single trigger, finish acquisition and then stop.

2.2 Connector



Figure 2-2 Connector

- **CH1, CH2:** for an input connector of a measured signal.
 - **EXT TRIG:** be used as an input connector of an external trigger source. Use [TRIG MENU] to select "EXT" or "EXT/5" trigger source, and the trigger signal source can be used for triggering in the third channel while acquiring data in two channels.
 - **Probe compensation:** The probe compensation signal is output and grounded so that the probe is matched with the channels of the oscilloscope.
- This product is grounded by a protective ground wire of a power cord. For avoiding electric shock, please ensure that the product is reliably grounded before connecting the input end or output end of the product.
 - The ground wire of the probe is connected to the ground only. Please do not connect the ground wire to high voltage.

2.3 Default setups

The default setups represent some option parameters that are set before the oscilloscope leaves factory for normal operations.



Figure 2-3 Default setup key

The [DEFAULT SETUP] key represents the default setup function, most of the options and control setups of the factory are recalled by pressing them, some setups are not changed, and the following setups are not reset:

- Language options
- Saved standard waveforms
- Saved setup files
- Contrast ratio of display screen
- Calibration data

2.4 UNIVERSAL knob

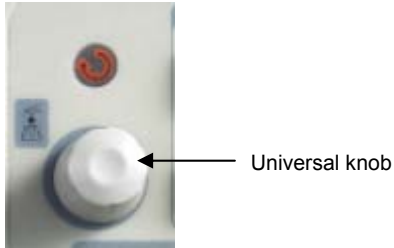

Figure 2-4 Universal knob

This series of digital storage oscilloscope has a special knob-[UNIVERSAL] knob by which the hold-off time, cursor measurement, pulse width setup, specified row in video trigger, upper limit and lower limit of filter frequency, horizontal tolerance range and vertical tolerance range for regulating PASS/FAIL function, waveform frame number recording and playback in waveform recording function and the like can be changed. The options for most of the menus can be selected by revolving the [UNIVERSAL] knob.

2.5 Vertical system

As shown in figure 2-5 below, a series of keys and knobs are in the vertical control region (VERTICAL).

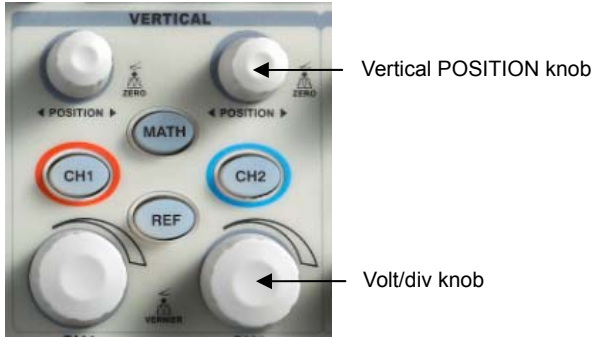

Figure 2-5 Vertical knobs

As seen in the figure above, each channel has individual vertical menu key and knob for regulating the vertical gear and offset. Moreover, the waveform display of the corresponding channel can be started or stopped by pressing [CH1] or [CH2].

2.5.1 Channels CH1 and CH2

Table 2-3 Function menu 1 of CH1 and CH2:





Option	setup	Description
Coupling	DC	Not only pass through the AC component of the input signal but also pass through the DC component of the input signal.
	AC	Reject DC component of the input signal and an AC signal lower than 10Hz.
	GND	Cut off the input signal.
Bandwidth limit	RUN	Limit the bandwidth to 20MHz, and reduce the noise.
	STOP	

	Coarse tuning	Define a 1-2-5 sequence: 2mv/div,5mv/div,...,5v/div.
Volt/div	Fine tuning	Fine tuning changes the resolution as small step in coarse tuning setup.
Probe	1X	The coefficient is matched with the attenuation coefficient of the probe used so as to obtain correct vertical reading.
	10 X	
	100 X	
	1000 X	
Next	Page1/2	Press the key to skip to page 2 of the menu.

Table 2-4 Function menu 2 of CH1 and CH2:

Option	setup	Description
Inverse	Run	Relative to the inverse-phase waveform of a reference electric level
	Stop	Stop the waveform inverse function
Digital filter		Press this key to skip to the digital filter menu (seen in table 2-5).
Back	Page2/2	Press the key to get back to page 1 of the menu.

Table 2-5 Digital filtration function menu:

Option	Setup	Description
Digital filter	Run	Run the digital filter
	Stop	Stop the digital filter
Filter type		Set the filter as low-pass filter
		Set the filter as high-pass filter
		Set the filter as band-pass filter
		Set the filter as band-reject filter
Filter Upper limit		Set the frequency upper limit using the [UNIVERSAL] knob
Filter lower		Set the frequency lower limit using the [UNIVERSAL]

limit	knob
Back	Back to the main digital filter main menu

- If the channel adopts a DC coupling mode, you can quickly measure the DC component of the signal by observing the difference between the waveform and the signal ground.
- If the channel adopts an AC coupling mode, the DC component in the signal is filtered. By this mode, the AC component of the signal is displayed at a higher sensitivity.
- If the channel adopts a GND coupling mode, cut off the input signal. Inside the channel, the channel input is connected with a zero volt reference electric level.

Setups of channels CH1 and CH2:

1. Setups of channel coupling

By using CH1 as an example, the measured signal is a sine signal with DC offset:

- Press [CH1]→“Coupling”→“AC”, and set an AC coupling mode. The DC component contained in the measured signal will be rejected, as shown in figure 2-6.
- Press [CH1]→“Coupling”→“DC”, and set a DC coupling mode. Both the DC component and the AC component contained in the measured signal can pass through the channel, as shown in figure 2-7.

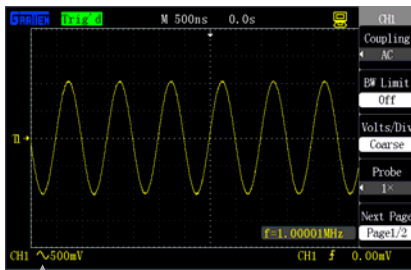

AC identification

Figure 2-6 Set AC

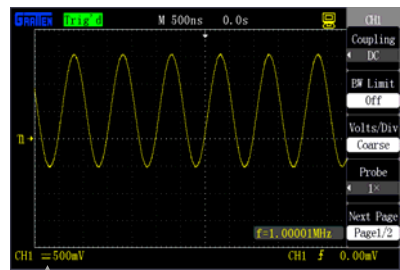

DC identification

Figure 2-7 Set DC

- Press [CH1]→“Coupling”→“GND”, and set a GNC mode. Both the DC component and the AC component contained in the measured signal are rejected, as shown in figure 2-8.

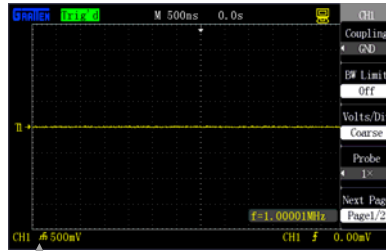

GND identification

Figure 2-8 Set GND

2. Setup of channel bandwidth limit

Using Channel CH1 as an example, the measured signal is a pulse signal with high-frequency oscillation:

- Press [CH1]→“Bandwidth limit”→“On”, and set the bandwidth limit as ON state. The amplitude of the high-frequency component higher than 20MHz contained in the measured signal is limited, as shown in figure 2-9.
- Press [CH1]→“Bandwidth limit”→“OFF”, and set the bandwidth limit as OFF state. The amplitude of the high-frequency component contained in the measured signal is unlimited, as shown in figure 2-10.

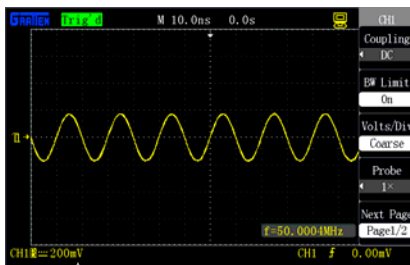

Bandwidth limit identification

Figure 2-9 Bandwidth limit ON

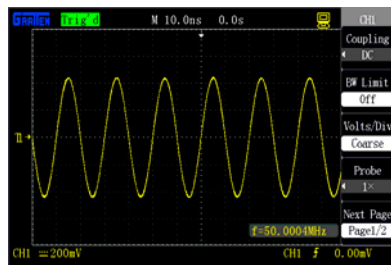

Figure 2-10 Bandwidth limit off

3. Regulation and setup of gear

Vertical gear regulation comprises two modes, including coarse tuning and fine tuning, and the vertical gear range is 2mV/div ~ 5V/div when the probe is set as 1X.

Use CH1 as an example:

- Press **[CH1]**→**"Volt/div"**→**"Coarse tuning"**, and determine the vertical gear by a 1-2-5 stepping mode in coarse tuning, as shown in figure 2-11.
- Press **[CH1]**→**"Volt/div"**→**"Fine tuning"**, and fine tuning is further regulated in the current vertical gear.

Fine tuning can be applied to improve waveform display so as to contribute to observation on signal details if the amplitude of the input waveform is a little larger than the full scale at the current gear but is a little smaller when the waveform is displayed at the next gear, as shown in figure 2-12.

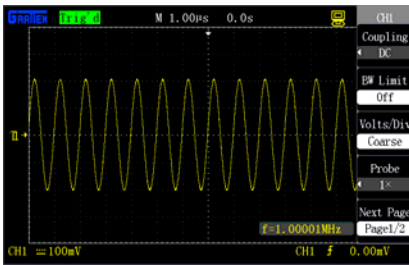

Figure 2-11 Coarse tuning

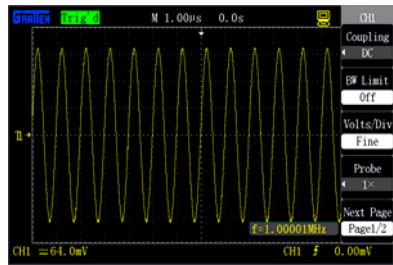

Figure 2-12 Fine tuning

4. Probe proportion setup

To be matched with the probe attenuation coefficient, the probe attenuation proportion coefficient should be accordingly regulated in the channel operation menu. If the probe attenuation coefficient is 10:1, the proportion of the input channel of the oscilloscope should be set as 10X so as to avoid the errors of the displayed gear information and the measured data.

Use channel CH1 as an example, when a probe (100:1) is used:

- Press **[CH1]**→**"Probe"**→**"100X"**, as shown in figure 2-13:

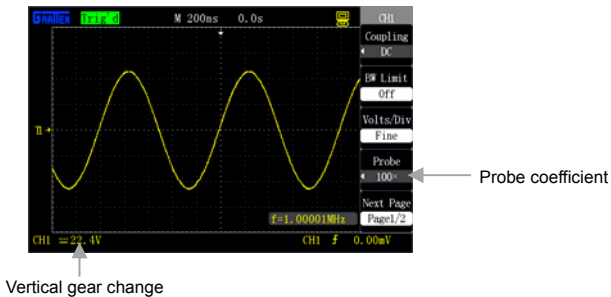

Figure 2-13 Probe 100X

5. Waveform inverse setup

Use channel CH1 as an example:

- Press [CH1]→“Inverse”→“OFF”, as shown in figure 2-14.
- Press [CH1]→“Inverse”→“ON”, and reverse the displayed signal by 180 degrees relative to zero electric level as reference, as shown in figure 2-15.

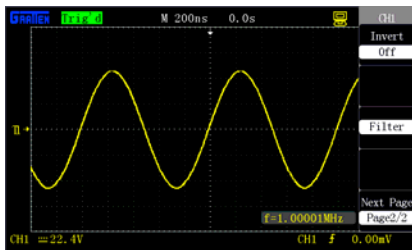

Figure 2-14 Inverse OFF

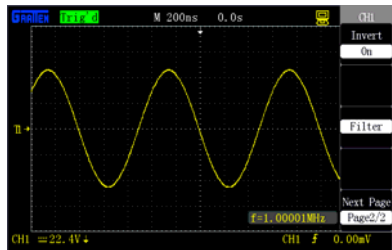

Figure 2-15 Inverse ON

6. Digital filter setup

- Press [CH1]→“Next”→“Digital filter”, and display digital filter function menu “FILTER”; select “Filter type”, then select “Frequency upper limit” or “frequency lower limit”, and revolve the [UNIVERSAL] knob to set the frequency upper limit and frequency lower limit.
- Press [CH1]→“Next”→“Digital filter”→“OFF”, and close the digital filter function, as shown in figure 2-16.
- Press [CH1]→“Next”→“Digital filter”→“ON”, and open digital filter function, as

shown in figure 2-17.

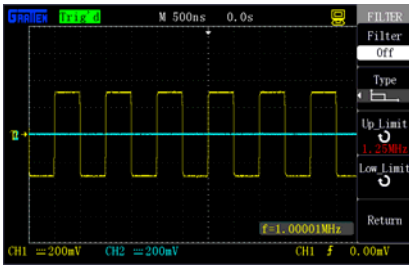

Figure 2-16 Digital filter OFF

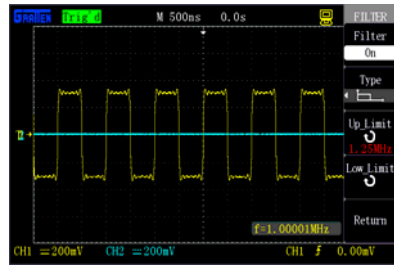

Figure 2-17 Digital filter ON

2.5.2 Application of [POSITION] knob and [Volt/div] knob of the vertical system

Vertical [POSITION] knob

1. The knob is used for regulating vertical offset of the waveform of the channel in where the knob is. The resolution is changed according to the vertical gear.
2. The knob can be pressed to return the vertical offset to zero.

[Volt/div] knob

1. The knob can be used for regulating the vertical gear of the channel in where the knob is so as to amplify or attenuate the signal of the channel waveform. The gear information of the channel is displayed in the lower part of the screen.
2. The knob can be pressed to switch between "Coarse tuning" and "Fine tuning", and the sensitivity of the vertical gear is determined by a 1-2-5 stepping mode in coarse tuning. Fine tuning represents further regulation at the current gear so as to display the waveform needed.

2.5.3 Implementation of MATH function

The arithmetical operation (MATH) function realizes waveform addition, subtraction, multiplication, division and FFT operation of channels CH1 and CH2. Arithmetical

operation of the waveform could be canceled by pressing [MATH] button again.

Table 2-6 MATH function menu



Option	Setup	Description
Operation	+,-,× ÷,FFT	Waveform operation of signal source 1 and signal source 2
		Regulate the vertical gear of the MATH waveform by the [UNIVERSAL] knob.
		Regulate the vertical offset of the MATH waveform by the [UNIVERSAL] knob.。

Table 2-7 Description of the arithmetical operation function:

Operation	Setup	Description
+	CH1+CH2	Add the waveform of signal source 1 with the waveform of signal source 2
-	CH1-CH2	Subtract the waveform of signal source 2 from the waveform of signal source 1
	CH2-CH1	Subtract the waveform of signal source 1 from the waveform of signal source 2
×	CH1×CH2	Multiply the waveform of signal source 1 with the waveform of signal source 2
÷	CH1÷CH2	Divide the waveform of signal source 1 by the waveform of signal source 2
	CH2÷CH1	Divide the waveform of signal source 2 by the waveform of signal source 1
FFT		Fast Fourier transform operation

Waveform addition of CH1 and CH2 is shown in figure 2-18:

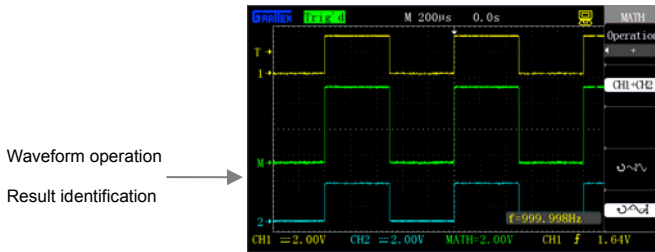

Figure 2-18 MATH Waveform addition

FFT Spectral analysis

Use FFT (Fast Fourier Transform) to transform a time domain (YT) signal into a frequency component (frequency spectrum). The following types of signals can be observed at FFT mode:



- Analyze harmonic wave in the power cord.
- Measure the harmonic wave component and distortion in the measurement system.
- Analyze the noise characteristics in a DC power supply.
- Test the pulse response of the system.
- Analyze vibration.

Table 2-8 Page 1 of the function menu FFT:

FFT Option	Setup	Description
Signal source	CH1 CH2	Select CH1 or CH2 as signal source
Window	Hanning Hamming Rectang Blackman	Select window type FFT
Horizontal amplification	1× 2× 5× 10×	Change the horizontal amplification factor of FFT result waveform

Next	Page 1/2	Skip to page 2 of the function menu FFT
------	----------	---

Table 2-9 Page 2 of the function menu FFT:

FFT Option	Setup	Description
Vertical scale	Vrms	Set Vrms as vertical scale unit
	dBVrms	Set dBVrms as vertical scale unit
		Regulate FFT waveform spectrum amplitude gear by [UNIVERSAL] knob
		Regulate FFT waveform spectrum offset by [UNIVERSAL] knob
Back	Page 2/2	Back to page 1 of the function menu FFT

FFT Window

As the oscilloscope is used for FFT transformation on waveform recording with finite length, the FFT algorithm is based on periodic signal. When the waveform period number within the finite length is an integer, YT waveform has the same amplitude at the start point and the end point, and no interruption is caused to the waveform. But when the period number is not an integer, the waveform has different amplitude at the start point and the end point, so that high-frequency transient interruption will be caused in the joint. In a frequency domain, this effect is named as leakage. Therefore, to avoid appearance of leakage, the original waveform is multiplied with a window function, and forcibly make the values at the start point and the end point be 0.

Determine to use what kind of window according to the item and source signal characteristics to be measured.

Table 2-10 Description of FFT window function

Window	Characteristics	Most suitable measuring points
Rectang	Best frequency resolution	Transient or short pulse where the signal electric level is approximately
	Worst amplitude	

	resolution Be equivalent to no use of window	equal there-before and there-after; constant-amplitude sine waves with nearly equal frequency.
Hanning	Better frequency resolution and worse amplitude resolution in comparison with rectangular window	Sine, period and narrow-band random noise.
Hamming	Frequency of window Hamming is a little better than that of window Hanning	Transient or short pulse where the signal electric levels are considerably different there-before and there-after
Blackman	Best amplitude resolution Worst frequency resolution	Single-frequency signal, find higher subharmonic

Carry out the following steps to use FFT mode:

Set time domain waveform

- Access the signal to CH1 or CH2, and press [AUTO] to display a YT waveform.
- Manually regulate the waveform display if necessary so as to ensure that the waveform does not surpass the screen and the screen displays a plurality of periods.
- According to Nyquist law, revolve [s/div] to make the sampling rate at least two times the frequency of the input signal.

Display FFT spectrum

- Press [MATH].
- Select "Operation" as "FFT".
- Select the signal source as "CH1" or "CH2".
- Select a suitable window function.

- Regulate spectrum amplitude gear and offset at page 2 of the FFT function menu so as to better observe FFT operation result.

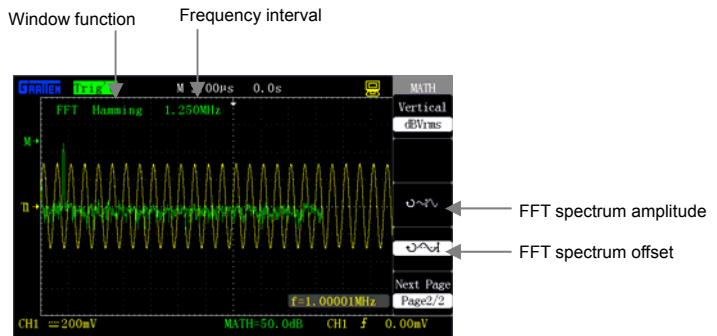

Figure 2-19 FFT

Use cursor to measure the FFT spectrum

Measure two items of the FFT spectrum: amplitude and frequency. The cursor measurement takes 2.11.2 for reference.

Use the horizontal cursor to measure the amplitude and use the vertical cursor to measure the frequency.

1. Measure FFT spectrum amplitude, and use CH2 as an example, the operation is as follows:

- 1) Input a sine signal to CH2, and press **[AUTO]**.
- 2) Press **[MATH]**, and skip to menu "MATH".
- 3) Press "Operation", and select "FFT".
- 4) Press "Signal source", and select "CH2".
- 5) revolve **[s/div]** to regulate the sampling rate (larger than double of the input frequency).
- 6) Press **[CURSORS]**, and skip to menu "CURSOR".
- 7) Press "Cursor mode", and select "manual".
- 8) Press "Type", and select "Voltage".

- 9) Press "Signal source", and select "MATH".
- 10) Press "CurA", and revolve the [UNIVERSAL] knob to move cursor A to the lowest point of the FFT waveform.
- 11) Press "CurB", and revolve the [UNIVERSAL] knob to move cursor B to the highest point of the FFT waveform.
- 12) The value of Delta V on the screen is the amplitude of the FFT waveform, as shown in figure 2-20.

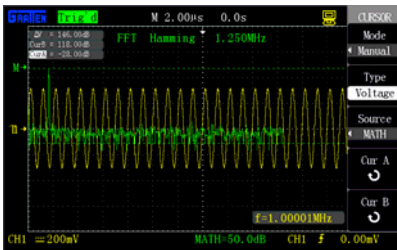

Figure 2-20 Cursor measurement of spectrum amplitude

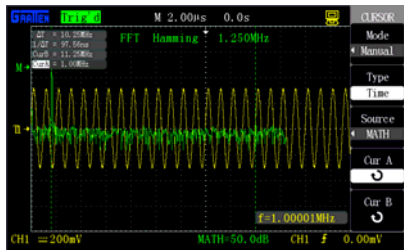

Figure 2-21 Cursor measurement of spectrum frequency

2. Measure the FFT spectrum frequency by the following steps:

- 1) Repeat previous steps 1-7 for measuring the spectrum amplitude.
- 2) Press "Type" and select "Frequency".
- 3) Press "Signal source" and select "FFT".
- 4) Press "CurA", and revolve the [UNIVERSAL] knob to move cursor A to the highest position of the FFT spectrum.
- 5) The value of CurA on the screen is the frequency of the highest point of the FFT spectrum, and the frequency should be equal to the frequency of the input signal, as shown in figure 2-21.

- A signal with DC component or offset will cause error or offset of an FFT waveform component. An AC coupling mode can be selected to reduce DC components.
- DBVrms vertical scale can be used for displaying the FFT waveform within a large dynamic range, and this scale displays the vertical amplitude at a logarithm mode.
- Nyquist Function: Reconstruction of the waveform needs to adopt a sampling rate that is double of the input frequency.

2.5.4 Implementation of REF function

During actual measurement, the waveform can be compared with the reference waveform so as to judge failure causes. This method is particularly applicable at a condition that detailed circuit working point reference waveforms are provided.

Table 2-11: REF function menu:

Option	Setup	Description
Signal source	CH1 CH2	Select the waveform for saving
REF A REF B		Select the reference of the saved or recalled waveform
SAVE		Save the signal source waveform in a selected reference position
REF A/REF B	RUN STOP	Display the standard waveform Stop the standard waveform

Press [REF] to display the reference waveform menu, as shown in figure 2-22:

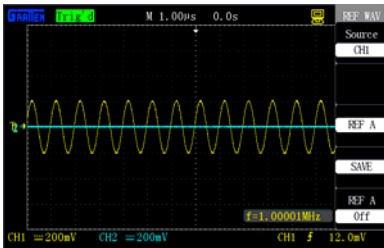

Figure 2-22 Reference waveform menu

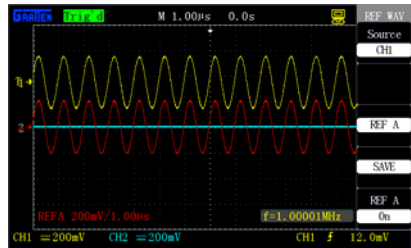

Figure 2-23 Reference waveform

Operation procedure:

1. Press [REF] to display the menu "REF WAV".
2. Select the "Signal source" as CH1 or CH2.
3. Revolve the vertical [POSITION] and knob [Volt/div] to regulate the vertical position and the gear of the reference waveform.
4. Select "REF A" or "REF B" as storage location of the reference waveform.
5. Press "Save" to save the current screen waveform as a waveform reference.
6. Select "REF A ON" or "REF B ON" to recall the reference waveform, as shown in figure 2-23.

- The waveform cannot be saved as reference waveform if it is displayed in an X-Y mode.
- The horizontal position and gear of the waveform cannot be regulated at a reference waveform state.

2.6 Horizontal system

As shown in the figure below, one key and two knobs are in the horizontal control region (HORIZONTAL).

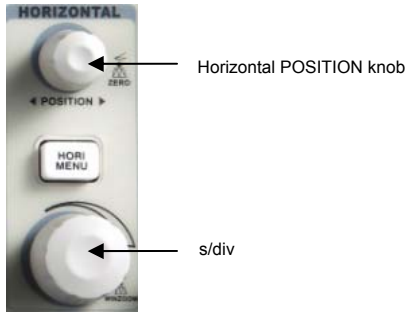

Figure 2-24 Horizontal key and knobs

[HORI MENU]

Press this key to display the horizontal menu "HORI MENU", and window expansion can be implemented at this menu. Besides, horizontal displacement can be set by the horizontal [POSITION] knob. M represents a main time base, and Z represents an expanded time base.

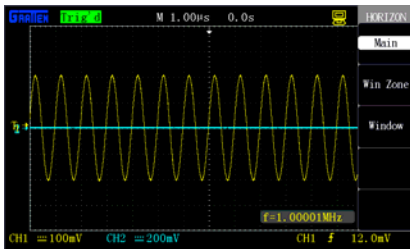

Figure 2-25 Main time base

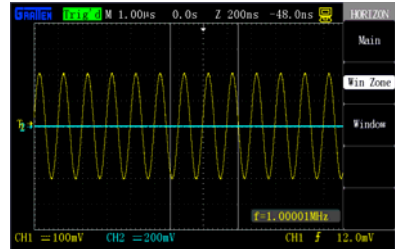

Figure 2-26 Window setup

Table 2-12 Functional menu of the horizontal system:

Option	Description
Main time base	Horizontal time scale system of the oscilloscope
Window setup	Define one window region by two cursors, and use the horizontal [POSITION] and the knob [s/div] to regulate the window

	region.
Window expansion	Expand the window setup region to the whole screen to increase the resolution relative to the main time base, so that the image details can be conveniently checked.

2.6.1 Horizontal control knob

The horizontal knob [s/div] changes the horizontal scale (time base), and the [POSITION] knob changes the horizontal position (triggered displacement) triggered in the internal memory. The center of the screen in the horizontal direction is a time reference point of the waveform. Change of the horizontal scale will cause expansion or contraction of the waveform relative to the center of the screen, while the change of the horizontal position is relative to the position of a trigger point.

Horizontal [POSITION] knob

1. Regulate the horizontal position (trigger the position relative to the center of the display screen) of the waveform (including MATH). The resolution of this control knob is changed according to the time base.
2. Use the press down function of this knob to make the horizontal displacement return to zero, namely back to the central position of the screen.

[S/div] knob

1. The knob is used for changing the horizontal time scale so as to conveniently observe the most suitable waveform.
2. The knob is used for regulating the main time base. When the window expansion mode is adopted, the knob is used for changing the expansion time base so as to change the window width.

Display Scan mode

When the time base is set to be 100ms/div or more slowly and the trigger mode is set to "Auto", the oscilloscope enters the scan mode. At this mode, waveform display is renewed from left to right. At the mode, no waveform trigger or horizontal position control exist. The channel coupling should be set as direct current when a

low-frequency signal is observed at the scan mode.

2.6.2 Window expansion

Window expansion is used for amplifying a segment of waveform so as to check details. The window expansion time base setup cannot be slower than the setup of the main time base. In the window expansion region, a selection region can be moved leftwards and rightwards by the horizontal [POSITION] knob or enlarged and reduced by revolving the [s/div] knob. The window expansion time base has higher resolution relative to the main time base. The smaller the window expansion time base is, the higher the horizontal expansion multiple of the waveform is.

Carry out the following steps to observe details of local waveform:

1. Press [HORI MENU] to display the "HORIZEN" menu.
2. Press the "WinZone" option button.
3. Revolve [s/div] (to regulate the size of the window) and the horizontal [POSITION] (to regulate the position of the window) to select the window of the waveform to be observed, as shown in figure 2-26. The expansion time base cannot be slower than the main time base.

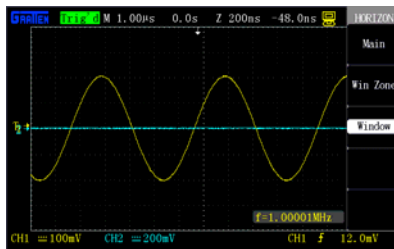

Figure 2-27 Window expansion

Press the "Window" button after the window is set. At the moment, the waveform in the selected window is expanded to the full screen to display. Figure 2-27 shows the expansion result after the window is set.

2.7 Trigger system

The trigger function of the oscilloscope can be synchronously horizontally scanned at the right point of the signal, which is very important to signal display. Trigger control can be used for stabilizing repeated waveform and acquiring single-pulse waveform. After the trigger is correctly set, the oscilloscope can transform an unstable display result or blank as a significant waveform.

As shown in the figure below, one knob and three keys are in the trigger control region (TRIGGER).

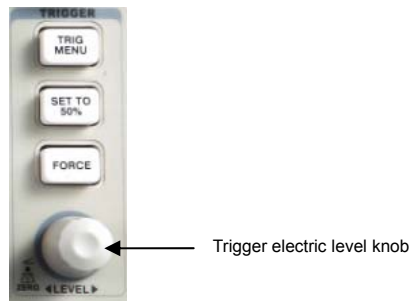

Figure 2-28 Trigger keys and knob

[TRIG MENU]

Press the key to recall the "TRIGGER" menu.

[LEVEL] knob

Set a signal voltage corresponding to the trigger point to the trigger electric level for sampling. Press the knob to set the trigger electric level as zero electric level.

[SET TO 50%]

Use the key to quickly stabilize the waveform. The oscilloscope could automatically trigger the electric level as a center electric level of the signal. The key is very useful and can be used for quickly setting the trigger electric level.

[FORCE]

No matter whether the oscilloscope detects the trigger, the key can be pressed to perform force trigger once so as to finish acquisition of the current waveform. The key is mainly applied to "Normal" and "Single" in the trigger modes.

Pre-trigger/delay trigger

The key is used for triggering the sampled data before/after the event.

The trigger position is generally set in the horizontal center of the screen, so that the pre-trigger and delay information can be observed. The horizontal [POSITION] knob can be further revolved to regulate horizontal displacement of the waveform so as to check more pre-trigger information or delay trigger information. For instance, if burrs generated by the circuit are caught, the causes of generation of the burrs may be found out by observing and analyzing the pre-trigger data.

Attention: pre-trigger and delay trigger are invalid at a slow scan state.

2.7.1 Signal source

The "Signal source" option can be used for selecting a signal as a trigger source for the oscilloscope. The signal source may be any signal connected to channels BNC(CH1,CH2), external triggers BNC(EXT,EXT/5) or an AC power line (AC Line is only used for "Edge" trigger). The EXT/5 setup option is used for expanding the external trigger electric level range.

2.7.2 Types

This series of oscilloscopes provide five trigger types: Edge, Pulse, Video, Slope and Alternation.

1. **Edge trigger:** the most basic as well as the most common trigger type, as shown in figure 2-29.

Table 2-13 Edge trigger function menu:

Option	Setup	Description
Type	Edge	Edge trigger happens when a trigger input signal crosses the trigger electric level at a rise edge or a fall edge.
Signal source	CH1	Triggers on a channel whether or not the waveform is displayed
	CH2	
	EXT	Does not display the trigger signal; the Ext option uses the signal connected to the EXT TRIG front panel BNC and allows a trigger level range of -12V to +12V
	EXT/5	Same as Ext option, but attenuates the signal by a factor of five, and allows a trigger level range of +6V to -6V. This extends the trigger level range.
	AC Line	This selection uses a signal derived from the power line as the trigger source; trigger coupling is set to DC and the trigger level to 0 volts.
Slope	Rise edge	Trigger the signal at the rising edge.
	Fall edge	Trigger the signal at the falling edge.
	Rise and fall edge	Trigger the signal at the rising edge and the falling edge.
Trigger modes	Auto	Automatic trigger can be implemented to finish acquisition at the mode when no valid trigger exists.
	Normal	Only valid triggered waveform is checked at the mode. The waveform is acquired only when satisfying the trigger condition.
	Single	Acquire a waveform when detecting a single trigger, and then stop.
Setup		Skip to the trigger setup menu.

Table 2-14 Trigger setup function menu:

Option	Setup	Description
--------	-------	-------------

	DC	All the components of a passing signal.
	AC	Reject DC components, and attenuate the signals lower than 50Hz.
Coupling	High-frequency rejection	Attenuate high-frequency components higher than 150kHz.
	Low-frequency rejection	Reject DC components, and attenuate low-frequency components lower than 7kHz.
Trigger hold-off		Use the [UNIVERSAL] knob to regulate the hold-off time
Reset		Reset the trigger hold-off time to be the minimal value 100ns
Back		Back to the homepage of the trigger menu

Operation steps:

Set the types

- 1) Press **[TRIG MENU]** to display the **"TRIGGER"** menu.
- 2) Press **"Type"** to select **"Edge"** trigger.

Set the signal sources

- 3) Press "Signal source" to select **"CH1", "CH2", "EXT", "EXT/5" or "AC Line" according to the signal input.**

Set the slopes

- 4) Press **"Slope"** to select **"Rise edge", "Fall edge" or "Rise and fall edge"**.

Set the trigger modes

- 5) Press **"Trigger mode"** to select **"Auto", "Normal" or "Single"**.

Auto: Refresh the waveform no matter whether the waveform satisfies the trigger condition.

Normal: Refresh the waveform when the waveform satisfies the trigger condition, otherwise, do not refresh the waveform and wait for occurrence of the next trigger event.

Single: Acquire the waveform once when the waveform satisfies the trigger condition, and then stop.

Set the trigger coupling

- 6) a. Press **"Setup"** to skip to the trigger setup menu.
- b. Press "Coupling" option key to select "DC", "AC", "HF rejection" or "LF rejection".

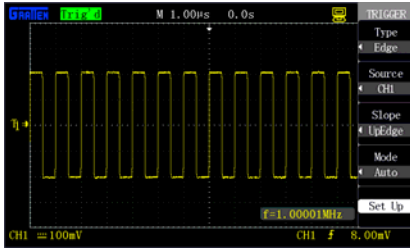

Figure 2-29 Edge trigger

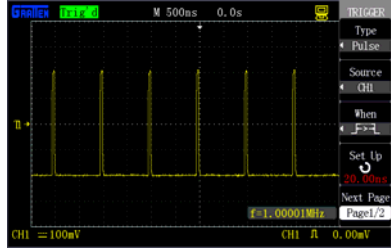







Figure 2-30 Pulse trigger

2. **Pulse trigger:** Set certain conditions to catch abnormal pulses, as shown in figure 2-30.

Table 2-15 Page 1 of the pulse trigger function menu:

Option	Setup	Description
Type	Pulse	Trigger the pulse satisfying the condition when selecting pulse.
Signal source	CH1	See the signal source shown in 2.7.1.
	CH2	
	EXT	
	EXT/5	
Condition	 Positive pulse width >	Condition for triggering the pulse relative to "Pulse width setup" value
	 Positive pulse width <	
	 Positive pulse width =	
	 Negative pulse width >	
	 Negative pulse width <	
	 Negative pulse width =	
Pulse width setup	20.0ns ~ 10.0s	Select the options to use the [UNIVERSAL] knob to set the pulse width

Next	Page 1/2	Skip to page 2 of the pulse trigger function menu
------	----------	---

Table 2-16 Page 2 of the pulse trigger function menu:







Option	Setup	Description
Type	Pulse	Trigger the pulse satisfying the condition when selecting pulse.
Trigger mode	Auto	See table 2-13. The "Normal" mode is most applicable to application of most of the "Pulse width" trigger.
	Normal	
	Single	
Setup		Skip to the trigger setup menu (See table 2-14).
Back		Back to page 1 of the pulse trigger menu.

Operation description:

Set the type:

- 1) Press **[TRIG MENU]** to display "TRIGGER" menu.
- 2) Press "Type" to select "Pulse".
Setup of the pulse trigger is similar with that of the edge trigger.

Set the condition:

- 3) Press the "Condition" option key to select "  " (positive pulse width <), "  " (positive pulse width >), "  " (positive pulse width =), "  " (negative pulse width <), "  " (negative pulse width >) or "  " (negative pulse width =).



Set the pulse width:

- 4) Revolve the **[UNIVERSAL]** knob to set the pulse width.
Press "Next Page 1/2" to skip to page 2 of the pulse trigger menu, and set the

trigger mode and the trigger coupling like the setup of the edge trigger.

Video trigger. Perform field or row video trigger on a standard video signal.

Table 2-17 Page 1 of the video trigger function menu:

Option	Setup	Description
Type	Video	Trigger an NTSC or PAL standard video signal when selecting video, and preset the trigger coupling as alternating current.
Signal source	CH1 CH2 EXT EXT/5	See the signal source in 2.7.1.
Polarity	 Standard  Inverse phase	Trigger under negative synchronous pulse Trigger under positive synchronous pulse
Synchronization	All rows Specified row Odd field Even field	Select suitable video for synchronization
Next	Page 1/2	Skip to page 2 of the video trigger function menu.

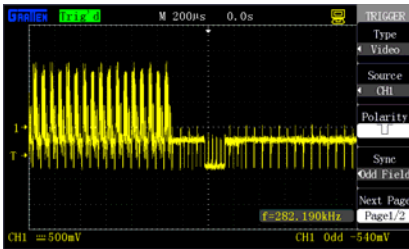

Figure 2-31 Page 1 of video trigger menu

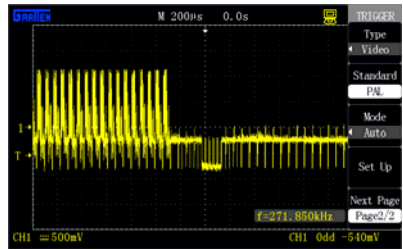

Figure 2-32 Page 2 of video trigger menu

Table 2-18 Page 2 of the video trigger function menu:

Option	Setup	Description
Type	Video	Trigger an NTSC or PAL standard video signal when selecting video, and preset the trigger coupling as alternating current.
Standard	NTSC PAL	Select video standard for synchronization and row counting.
Trigger mode	Auto Normal Single	See the trigger mode in table 2-13.
Setup		Skip to the trigger setup menu (See table 2-14).
Back	Page 2/2	Back to page 1 of the video trigger function menu.

Operation description



As show in figures 2-31, 2-32:

Set the types:

- 1) Press **[TRIG MENU]** key to display **"TRIGGER"** menu.
- 2) Press **"Type"** to select **"Video"**.

Setup of the signal source of the video trigger is like that of the edge trigger.

Set the polarity:

- 3) Press "Polarity" to select  " or '  ".

Set the synchronization:







- 4) Press "Synchronization" to select "All row", "Specified row", "Odd field" or "Even field". Revolve the [UNIVERSAL] knob to set the number of the specified rows if "Specified row" is selected.

Set the standard:

- 5) Press **"Next Page 1/2"**.
- 6) Press **"Standard"** to select **"PAL"** or **"NTSC"**.

Slope trigger

Table 2-19 Page 1 of the slope trigger function menu:

Option	Setup	Description
Type	Slope	
Signal source	CH1 CH2 EXT EXT/5	See the signal source in 2.7.1.
Conditions	 Positive slope>  Positive slope<  Positive slope=  Negative slope>  Negative slope<  Negative slope=	Conditions of signal slope relative to set slope (set by time)
Time setup	<Set time>	Revolve the [UNIVERSAL] knob to set the slope time. Time setup range: 20ns-10s.
Next	Page 1/2	Skip to page 2 of the slope trigger menu.

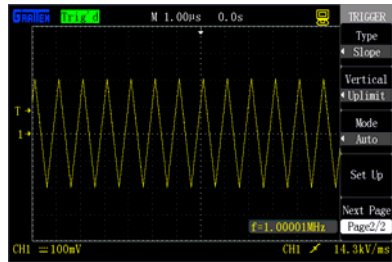
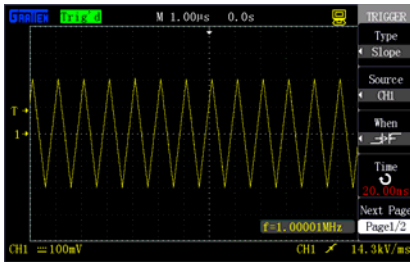

Figure 2-33 Page 1 of slope trigger menu Figure 2-34 Page 2 of slope trigger menu

Table 2-20 Page 2 of the slope trigger function menu:

Option	Setup	Description
Type	Slope	
Vertical window	Upper boundary Lower boundary Upper and lower boundaries	Select boundary, and regulate the size of the window by the [LEVEL] knob.

	Auto	
Trigger mode	Normal	See the trigger mode in table 2-13.
	Single	
Setup		Skip to the trigger setup menu (See table 2-14).
Back	Page 2/2	Back to page 1 of the slope trigger menu.

Operation description:

Carry out the following steps to select "Slope trigger" type:

1. Input a signal to channel 1 or channel 2.
2. Press [AUTO].
3. Press [TRIG MENU] to skip to "TRIGGER" menu.
4. Press "Type" to select "Slope".
5. Press "Signal source" to select "CH1" or "CH2".
6. Press "Condition" to select slope condition.
7. Press "Time setup", and revolve the [UNIVERSAL] knob to regulate the slope time.
8. Press "Next Page1/2" to skip to Page 2 of the slope trigger menu.
9. Press "Vertical window" to select window boundary.
10. Revolve the trigger electric level [LEVEL] knob until the waveform is stably triggered.

Alternating trigger

When alternating trigger is selected, the trigger signal comes from two channels. The mode is used for simultaneously observing two unrelated signals. Two different trigger types (edge, pulse, video and slope) can be selected for the signals from the two channels. During setup, the trigger types of the two channels and the trigger electric level information are respectively displayed in the right lower corner of the screen. The setups of the four trigger types are seen in 2.7.2.

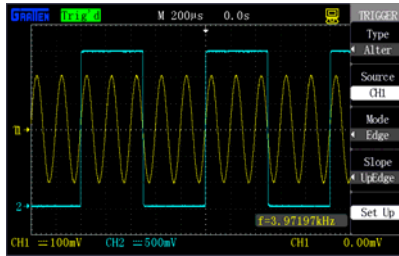

Figure 2-35 Alternating trigger

Operation description:

As shown in figure 2-35, the following steps can be carried out for simultaneously observing unrelated signals in two channels:

1. Access two unrelated signals to channel 1 and channel 2.
2. Press [AUTO].
3. Press [TRIG MENU] to skip to "TRIGGER" menu.
4. Select the trigger "Type" as "Alternation".
5. Select the "Signal source" as "CH1".
6. Press "Trigger mode" to select "Edge", "Pulse", "Slope" or "Video".
7. Perform setup to realize stable trigger.
8. Select the "Signal source" as "CH2".
9. Repeat step 6, press "Trigger mode" to select "Edge", "Pulse" or "Video".
10. Repeat step 7.

2.7.3 Coupling

The "Coupling" option is used to determine which part of signal passes through the trigger circuit. It is conducive to stably display the waveform. Press [TRIG MENU] to use trigger coupling. Select the "Coupling" option in the "Setup" menu after selecting the trigger type, including DC coupling, AC coupling, HF rejection and LF rejection. The functions of all the options are specifically shown in table 2-14.

2.7.4 Trigger hold-off

The trigger hold-off function is used for stably displaying complex waveform. The hold-off time represents a time interval between twice trigger detected by the oscilloscope. During the hold-off period, the oscilloscope performs no trigger. As shown in figure 2-36 below, regulate the hold-off time according to one pulse sequence so that the oscilloscope only triggers at the first pulse in the row.

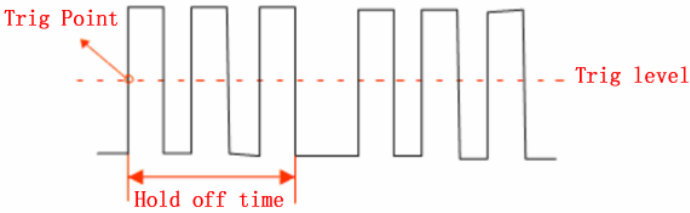

Figure 2-36 Trigger hold-off schematic figure

Carry out the following steps to change the hold-off time:

1. Press [TRIG MENU] to display the "TRIGGER" menu.
2. Press "Type" to select the trigger type.
3. Press the "Setup" option to skip to the trigger setup menu.
4. Press the "Trigger hold-off" function.
5. Regulate the [UNIVERSAL] knob to change the hold-off time until the waveform is stably triggered.

- Using the trigger hold-off is conducive to stably display non-periodic signals.

2.8 Signal acquisition system

[ACQUIRE] is a function key of the signal acquisition system.

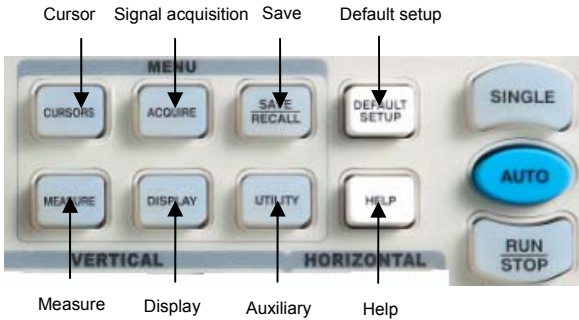

Figure 2-37 Menu keys

Table 2-28 function keys of the signal acquisition system:

Option	Setup	Description
Acquisition mode	Sampling	For acquiring and accurately displaying waveform
	Peak value detection	For detecting burrs and reducing "Fake wave phenomenon".
	Average value	For reducing random or unrelated noise in signal display.
	Average time (4 , 16 , 32 , 64 , 128 , 256)	Select average time.
Interpolation type	Sine	Enable sine interpolation
	Linear	Enable linear interpolation
Sampling mode	Real-time sampling	Set the sampling mode as real-time sampling
Sampling rate		Display the sampling rate of the system

- **Sampling:** The oscilloscope samples the signal at uniform time intervals to form a waveform.

Advantage: Signals can be accurately shown at the mode in many cases.

Shortcoming: Quickly changing signals possibly generated between sampling points cannot be acquired at the mode, which may cause “fake wave phenomenon” and may miss spike pulses, so “peak value detection” mode should be adopted under these conditions.

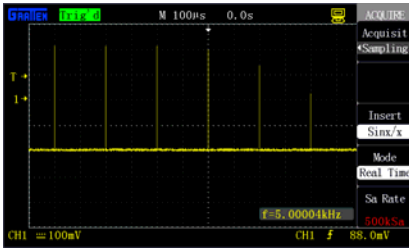

Figure 2-38 Sampling mode

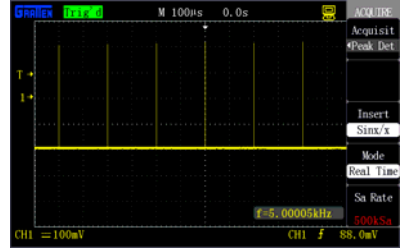

Figure 2-39 Peak value detection mode

- **Peak value detection:** The oscilloscope finds out the maximal value and the minimal value of the input signal in each sampling interval and uses these values to display the waveform.

Advantage: spike pulses that may be missed can be acquired and displayed and signal confusion can be avoided at the mode.

Shortcoming: Loud noise is displayed at the mode.

- **Average value:** The oscilloscope acquires a plurality of waveforms and displays the final waveforms after averaging the waveforms.

Advantage: Random or unrelated noises in the displayed signal can be reduced at the mode. The signal shown in figure 2-40 has loud noises, while the signal shown in figure 2-41 adopts the average mode, so the noises are greatly reduced. What calls for attention is that: the higher the average time is, the better the waveform quality is, but the slower the refreshing speeds of the waveform is.

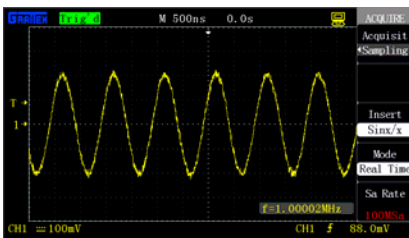

Figure 2-40 Sampling mode

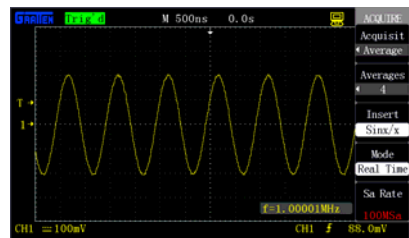

Figure 2-41 Average mode

- **Real-time sampling:** The real-time sampling mode realizes suffusion of the storage space during each sampling. The real-time sampling rate is at most 1GSa/s.
- **[RUN/STOP]:** Press the key to start continuous data acquisition or stop acquisition.
- **[SINGLE]:** Press the key after the oscilloscope detects the trigger and stop after wave acquisition is finished once.

When **[RUN/STOP]** or **[SINGLE]** is pressed to start acquisition, the oscilloscope executes the following steps:

1. Acquire enough data to fill the waveform part before the waveform is triggered, which is also named pre-trigger.
 2. Continue to acquire data when waiting for trigger.
 3. Detect the trigger conditions.
 4. Continue to acquire data before the storage space is full.
 5. Display the lately acquired waveform.
- **Time base:** Use the [s/div] knob to regulate the time base. The time base is a quantization unit of the time, namely the time represented by a large horizontal grid (this series of oscilloscope has 14 horizontal grids in total) of the oscilloscope. The time base is closely related with the sampling rate. The larger the time base is, and the smaller the sampling rate is.
 - **Fake wave phenomenon:** Fake wave phenomenon will appear if the oscilloscope does not sample the signal quickly enough and does not make accurate waveform recording, as shown in figure 2-42. To eliminate this type of phenomenon, switch to a quick time base gear or adopt the peak value detection mode.

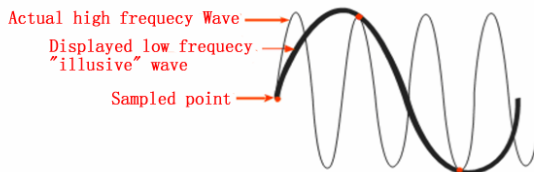

Figure 2-42

Select a suitable interpolation function:

At a small time base gear (50ns/div or smaller), there are few original sampling points in one period and the displayed waveform has bad quality, so an interpolation function is adopted to increase "sampling point" and rebuild the waveform, so that the measurement precision is improved. Sine interpolation is suitable for sine, while linear interpolation is suitable for triangular wave, square wave and **similar**. As shown in figure 2-43 below, after sine interpolation, the displayed waveform is good, while figure 2-44 shows the waveform after linear interpolation of a sine signal, absolutely, the waveform is bad, and the interpolation function is not selected rightly.

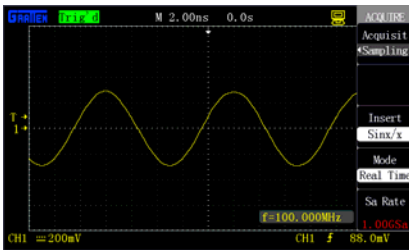

Figure 2-43 Sine interpolation

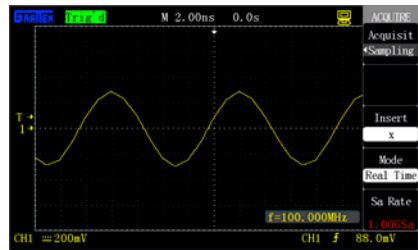



Figure 2-44 Linear interpolation

2.9 Display system

[DISPLAY] is a function key of the display system.

Image of the location of the Key?

Table 2-29 Page 1 of the display system function menu:

Option	Setup	Description
Type	Vector	The sampling points are displayed in a link line manner.
	Point	No interpolation link line is displayed between the sampling points. Display sample points directly
Persist	OFF	Set the maintained display time length of each displayed sampling point.
	1s	
	2s	
	5s	
	Infinite	
Intensity		Set the waveform brightness by the [UNIVERSAL] knob.
Grid brightness		Set the grid brightness by the [UNIVERSAL] knob.
Next	Page 1/2	Skip to the next page.

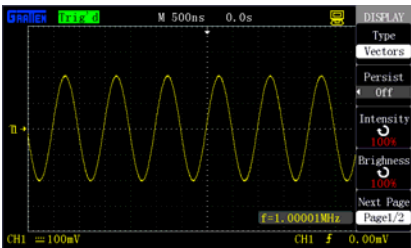

Figure 2-45 Page 1 of the display menu

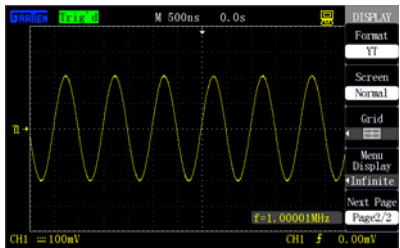





Figure 2-46 Page 2 of the display menu

Table 2-30 Page 2 of the display system function menu:

Option	Setup	Description
Format	YT	The YT format is used for displaying the vertical voltage relative to the time (horizontal scale).
	XY	The XY format is used for displaying the points sampled in channel 1 and channel 2.
Screen	Normal	The screen is at a normal display mode.
	Inverse	The screen is at an inverse display mode.
Grid		Display the background grid and coordinates.
		Turn off the background grid.
		Turn off the background grid and coordinates.
Menu display	2s	Set the duration time of the menu display.
	5s	
	10s	
	20s	
	Infinite	
Back	Page 2/2	Back to page 1 of the display system function menu.

Operation description:

Set the waveform display types:

Press [DISPLAY] to skip to the "DISPLAY" menu, and press "Type" to select "Vector" or "Point".

Set continue:

Press "Continue" to select "OFF", "1s", "2s", "5s" or "Infinite". By utilizing the option, some special waveforms can be observed, as shown in figure 2-47.

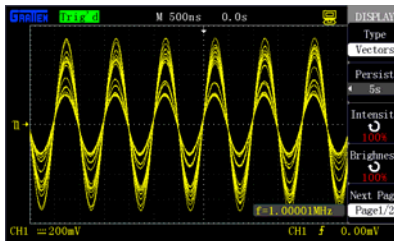

Figure 2-47 Utilize the continue option to observe amplitude modulated wave

Set the waveform brightness:

Press "**Wave brightness**", and revolve the **[UNIVERSAL]** knob to regulate the display brightness of the waveform.

Set the grid brightness:

Press "**Grid brightness**", and revolve the **[UNIVERSAL]** knob to regulate the display brightness of the grid.



Set the display format:

Press "**Next Page1/2**" to skip to page 2 of the display menu. Press "**Format**" to select "**YT**" or "**XY**".

Set the screen:

Press "**Screen**" to select "**Normal**" or "**Inverse**" to set the color of the screen.

Set the grid:

Press the "**Grid**" option key to select "  ", "  " or "  " to set whether the grid is displayed on the screen.

Set the menu display:

Press the "**Menu display**" option key to select "**2s**", "**5s**", "**10s**", "**20s**" or "**Infinite**" to set the maintained display time length of the menu on the screen.

2.9.1 X-Y mode

Use the XY format to analyze phase difference. At the format, the voltage of channel 1 determines coordinate X (horizontal) of a point, while the voltage of channel 2 determines coordinate Y (vertical) of the point. The oscilloscope uses a non-triggered sampling mode to display the data as a spot. Figure 2-48 shows the YT mode, and it shows that signals of the two channels have the same amplitude and frequency and the phase difference is 90 degrees. After switching to X-Y mode, the waveform is shown in figure 2-49 below.

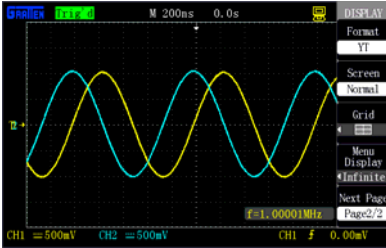

Figure 2-48 Y-T mode

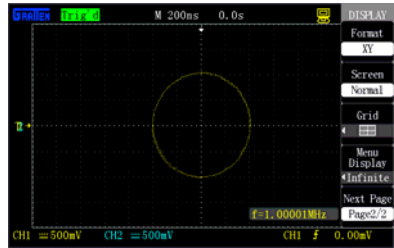

Figure 2-49 X-Y mode

- The oscilloscope can acquire the waveform according to a normal YT mode at any sampling rate and can check the corresponding waveform at XY mode.

Control operation is as follows:

- The [Volt/div] and the vertical [POSITION] of channel 1 control the setup of the horizontal scale and position.
- The [Volt/div] and the vertical [POSITION] of channel 2 control the setup of the vertical scale and position.
- Revolve the [s/div] knob to regulate the sampling rate so as to observe the waveform better.

In XY display format, the following functions are not available:

- Waveform arithmetical operation
- Cursor
- Auto setup (the display format is reset as YT)
- Trigger control
- Horizontal position knob
- Vector display type
- Scan type display

At the vector display mode, the oscilloscope connects the sampling points in a digital interpolation manner, and the interpolation manner includes linear interpolation and sine interpolation. The sine interpolation manner is suitable for the real-time sampling mode and is available at a time base of 50ns or faster at the real-time sampling mode.

2.10 Measurement system

The oscilloscope can use scale and cursor for measurement or automatic measurement, so that users can fully understand the measured signals.

2.10.1 Scale measurement

By using the method, estimation can be made quickly and intuitively. For instance, waveform amplitude can be observed, and a probable measurement result is judged according to the vertical scale. The method realizes simple measurement by multiplying the vertical scale number of the signal with the vertical gear Volt/div.

2.10.2 Cursor measurement

[CURSORS] is a function key for cursor measurement.

The cursor measurement includes two modes: **Manual mode** and **Tracking mode**.

1. Manual mode:

Horizontal cursors or vertical cursors appear in pair to measure time or voltage, and the distance between the cursors can be manually regulated. The signal source should be set as a waveform to be measured before the cursors are used.



2. Tracking mode:

A horizontal cursor is intersected with a vertical cursor to form a cross cursor. The cross cursor is automatically located on the waveform, and the horizontal position of the cross cursor on the waveform is regulated by selecting "Cur A" or "Cur B" and rotating the [UNIVERSAL] knob. The coordinates of the cursor point will be displayed on the screen of the oscilloscope.

Manual cursor measurement mode

Table 2-32 Manual cursor measurement function menu:

Option	Setup	Description
Cursor mode	Manual	Set the manual cursor measurement
Types	Voltage	Manually use the cursor to measure voltage parameters.

	Time	Manually use the cursor to measure time parameters.
Signal sources	CH1	Select the input channel of the measured signal.
	CH2	
	MATH	
	REF A	
	REF B	
Cur A		Select the option using the [UNIVERSAL] knob to regulate the position of cursor A.
Cur B		Select the option using the [UNIVERSAL] knob to regulate the position of cursor B.

The manual cursor measurement mode is used for measuring the coordinate values and increments of one pair of horizontal or vertical cursors. Ensure the signal source to be set rightly when using the cursors, as shown in figure 2-50.

- **Voltage cursor:** The voltage cursor appears on the display screen as a horizontal line, and it can be used for measuring vertical parameters.
- **Time cursor:** The time cursor appears on the display screen as a vertical line, and it can be used for measuring horizontal parameters.
- **Cursor movement:** Select the cursors first and use the [UNIVERSAL] knob to move cursor A and cursor B, wherein the values of the cursors will appear on the right upper corner of the screen during movement.

The operation steps are as follows:

1. Press [CURSORS] to skip to the "CURSOR" menu.
2. Select "Cursor mode" as "manual".
3. Press "Type" to select "Voltage" or "Time".
4. Press "Signal source" to select CH1, CH2, MATH, REF A or REF B according to the signal input channel.
5. Select "Cur A" and revolve the [UNIVERSAL] knob to regulate the position of

cursor A.

6. Select **"Cur B"** and revolve the **[UNIVERSAL]** knob to regulate the position of cursor B.
7. Display the measured values on the left upper corner of the screen.

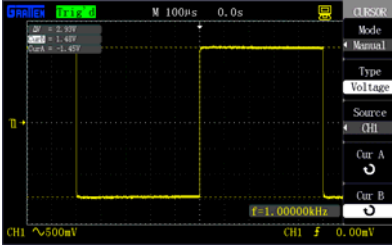

Figure 2-50 Cursor manual mode

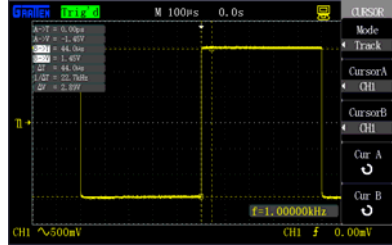

Figure 2-51 Cursor tracking mode

Cursor tracking measurement mode

Table 2-33 Cursor tracking function menu:

Option	Setup	Description
Cursor mode	Tracking	Set the tracking cursor measurement.
Cursor A	CH1	Set an input channel for cursor A to measure the signal by tracking measurement.
	CH2	
	No cursor	
Cursor B		Set an input channel for cursor B to measure the signal by tracking measurement.
Cur A		Select the option using the [UNIVERSAL] knob to regulate the horizontal coordinate of cursor A.
Cur B		Select the option using the [UNIVERSAL] knob to regulate the horizontal coordinate of cursor B.

At cursor tracking measurement mode, the cross cursors are displayed on the measured waveform, the cursors are automatically located on the waveform by moving the horizontal position between the cursors, and simultaneously the horizontal and vertical coordinates of the current located point, and the horizontal and vertical increments between the two cursors are displayed. The horizontal coordinate is displayed as a time value, and the vertical coordinate is displayed as a voltage value, as shown in figure 2-53.

The operation steps are as follows:

1. Press **[CURSORS]** to skip to the "CURSOR" menu.
2. Select "Cursor mode" as "Tracking".
3. Press "Cursor A", and select the input channel CH1 or CH2 of the tracked signal.
4. Press "Cursor B", and select the input channel CH1 or CH2 of the tracked signal.
5. Select "Cur A", and rotate the [UNIVERSAL] knob to horizontally move cursor A.
6. Select "Cur B", and rotate the [UNIVERSAL] knob to horizontally move cursor B.
7. Display the measured values on the left upper corner of the screen:

A→T : Position (namely the time based on the horizontal central position) of cursor A in the horizontal direction.

A→V : Position (namely the voltage based on the grounded point of the channel) of cursor A in the vertical direction.

B→T : Position (namely the time based on the horizontal central position) of cursor B in the horizontal direction.

B→V : Position (namely the voltage based on the grounded point of the channel) of cursor B in the vertical direction.

Delta T : Horizontal distance (namely the time value between the two cursors) of cursor A and cursor B.

1/Delta T : Frequency of cursor A and cursor B.

Delta V : Vertical distance (namely the voltage value between the two cursors) of cursor A and cursor B.

2.10.3 Measurement

As shown in figure 2-52, **[MEASURE]** is a function key for measurement.

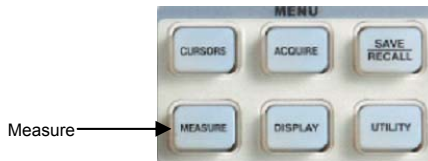

Figure 2-52 Measure keys

The measurement includes three major items: voltage measurement, time

measurement and delay measurement; and there are 32 measurement minor items in total. At most five items can be displayed once. Press [MEASURE] to skip to the measurement menu to display the measurement result at first, as shown in figure 2-53, and press any option key to change the measurement type, as shown in figure 2-54.

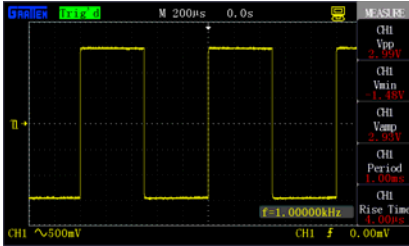

Figure 2-53 Measurement result

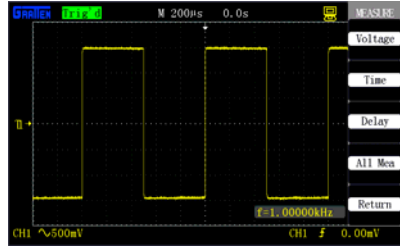

Figure 2-54 Measurement type

Table 2-35 Measurement function menu 1:

Option	Description
Voltage measurement	Press the key to skip to the voltage measurement menu.
Time measurement	Press the key to skip to the time measurement menu.
Delay measurement	Press the key to skip to the delay measurement menu.
All measurement	Press the key to skip to the all measurement menu.
Back	Press the key to get back to the measurement result.

Table 2-36 Measurement function menu 2-voltage test menu:

Option	Setup	Description
Signal source	CH1, CH2	Select a signal source for a voltage test.
types	Maximal value, minimal value, peak-to-peak value, amplitude, top value, bottom value, periodic average value, average value, periodic mean square root, mean square root, ROVERShoot, FOVERShoot, RPRESShoot, FPRESShoot	Press "Measurement type" or revolve the [UNIVERSAL] knob to select voltage measurement parameters.

	Display the icons and measured values corresponding to the selected voltage measurement parameters.
Back	Back to measurement function menu 1

Table 2-37 Measurement function menu 3-time test menu:

Option	Setup	Description
Signal source	CH1,CH2	Select a signal source for time measurement.
Types	Rise time, fall time, frequency, period, pulse width, positive pulse width, negative pulse width, positive duty ratio, negative duty ratio	Press " Measurement type " or revolve the [UNIVERSAL] knob to select time test parameters.
		Display the icons and the measured values corresponding to the selected measurement parameters.
Back		Back to the measurement function menu 1.

Table 2-38 Measurement function menu 4-delay test menu:

Option	Setup	Description
Signal source	CH1 CH2	Select a signal source for delay measurement.
Types	Phase, FRR, FRF, FFR,FFF,LRR, LRF,LFR,LFF	Press "Measurement type" or revolve the [UNIVERSAL] knob to select the delay measurement parameters.

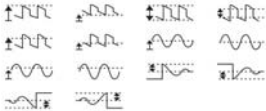



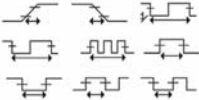

















	Display the icons and the measured values corresponding to the measurement parameters.
Back	Back to the measurement function menu 1.

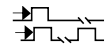



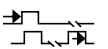

Table 2-39 All measurement function menu:

Option	Setup	Description
Signal source	CH1 CH2	Select the input signal channel.
Voltage measurement	Run	Run all measurement on the voltage type parameters.
	Stop	Stop all measurement on the voltage type parameters.
Time measurement	Run	Run all measurement on the time type parameters.
	Stop	Stop all measurement on the time type parameters.
Delay measurement	Run	Run all measurement on the delay type parameters.
	Stop	Stop all measurement on the delay type parameters.
Back		Back to the measurement function menu 1.

Table 2-40 Measurement types:

Measurement types	Description
Maximal value 	Peak forward voltage
Minimal value 	Peak inverse voltage
Peak-to-peak value 	Calculate the absolute difference between the maximal value and the minimal value of the whole waveform.
Top value 	Maximum voltage of the whole waveform
Bottom value 	Minimum voltage of the whole waveform

Amplitude		Voltage between the top value and the bottom value of the waveform
Periodic average value		Arithmetic mean value of the waveform in the first period
Average value		Calculate the arithmetic mean voltage in the whole recording.
Periodic mean square root		Namely an effective value. Calculate the actual mean square root value of the waveform in the first complete period.
Mean square root		Actual mean square root voltage of the whole waveform
ROVERShoot		Ratio of the difference of the maximal value and the top value of the waveform to the amplitude after rising
FOVERShoot		Ratio of the difference of the minimal value and the bottom value of the waveform to the amplitude after falling
RPREShoot		Ratio of the difference of the minimal value and the bottom value of the waveform to the amplitude before rising
FPREShoot		Ratio of the difference of the maximal value and the top value of the waveform to the amplitude before falling
Rise time		Measure the time between 10% and 90% of the first rise edge of the waveform.
Fall time		Measure the time between 90% and 10% of the first fall edge of the waveform.
Pulse width		Duration time of a burst pulse. Measure the whole waveform.
Positive pulse width		Measure the time between 50% of the electric level of the first rise edge and 50% of the electric level of an adjacent fall edge of the pulse.
Negative pulse width		Measure the time between 50% of the electric level of the first fall edge and 50% of the electric level of an adjacent rise edge of the pulse.
Positive duty ratio		Ratio of the positive pulse width to the period
Negative duty ratio		Ratio of the negative pulse width to the period
Phase		Periodically measure the time quantity that one waveform is earlier or later than another waveform, and use degree (°) to represent the

		time quantity, wherein 360 degrees form a period.
FRR		Time between the first rise edges of signal source 1 and signal source 2
FRF		Time between the first rise edge of signal source 1 and the first fall edge of signal source 2
FFR		Time between the first fall edge of signal source 1 and the first rise edge of signal source 2
FFF		Time between the first fall edges of signal source 1 and signal source 2
LRR		Time between the first rise edge of signal source 1 and the last rise edge of signal source 2
LRF		Time between the first rise edge of signal source 1 and the last fall edge of signal source 2
LFR		Time between the first fall edge of signal source 1 and the last rise edge of signal source 2
LFF		Time between the first fall edge of signal source 1 and the last fall edge of signal source 2

Carry out the following steps to measure the voltage parameters:

1. Press **[MEASURE]** key to skip to the “**MEASURE**” menu.
2. Press the first option key to skip to the measurement function menu 1 in a measurement result region in the homepage.
3. Select “**Voltage measurement**”.
4. Press “**Signal source**”, and select CH1 or CH2 according to the signal input channel.
5. Press “Measurement type” or revolve the **[UNIVERSAL]** knob to select the voltage parameters to be measured.

The corresponding icons and parameter values will be displayed in the menu corresponding to the third option key, as shown in figure 2-55.

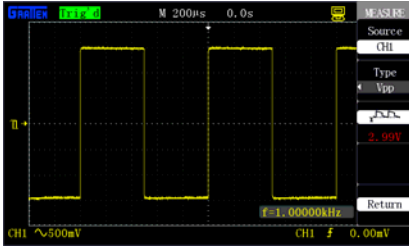

Figure 2-55 Specific item measurement

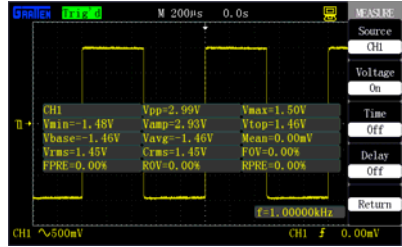

Figure 2-56 All measurement

6. When get back to the measurement result region in the homepage, the selected parameters and the corresponding values will be displayed in the first option.

Other option measurement types can be changed by the same method, and the homepage can display five parameters every time.

The voltage parameters can be measured by using the all measurement function by the following steps:

1. Press **[MEASURE]** to skip to the “MEASURE” menu.
2. Press any option key in the homepage to skip to the measurement function menu 1.
3. Select “All measurement”.
4. Press “Signal source” to select the signal input channel.
5. Press “Voltage test” to select “Run”. At the moment, all the voltage parameter values will be simultaneously displayed on the screen. (As shown in figure 2-56)

2.11 Storage system

[SAVE/RECALL] is a save/recall function key.

Table 2-41 Save type description:

Type	Description
Setup save	20 groups of setups can be saved in a format of .SET
Waveform save	16 groups of waveforms can be saved in a format of .DAV The waveform data can be recalled to the current oscilloscope or the same series of oscilloscope.
Image save	It is equivalent to screen capture, and the format is .BMP. It is only saved in a USB flash disc and opened by computer software.
CSV	The format is .CSV. It is only saved in a USB flash disc and opened by computer EXCEL software.
Factory setups	The factory setups are inherent in the oscilloscope when the oscilloscope leaves factory and are recalled only.

Waveform save: It is waveform data displayed on an interface and can be identified by the oscilloscope;

The saved image is the whole screen image (including waveform, menu and the like);

The CSV saves the original data points of the waveform.

Save/recall setup

■ Save types

The save types include setup save, waveform save, image save, CSV and factory setups, wherein the setups and waveforms can be saved and then recalled, the images and CSV are saved only, and the factory setups are recalled only.

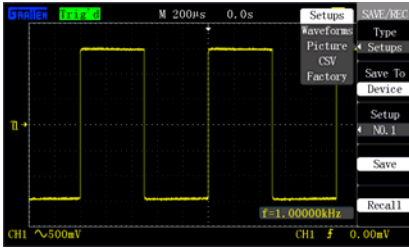

Figure 2-57 Save type

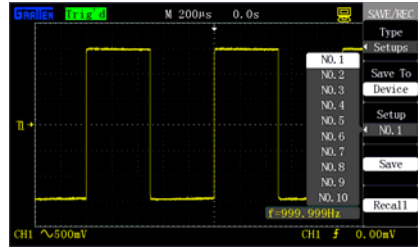

Figure 2-58 Save to equipment

■ **Save the setups in equipment:**

As shown in figure 2-58, the setups are saved in equipment (the equipment is the oscilloscope), and 20 groups of data (NO.1-NO.20) can be saved. The save steps are as follows:

1. Press **[SAVE/RECALL]** to skip to the **"SAVE/RECALL"** display menu.
2. Press **"Type"** to select **"Setup save"**.
3. Press **"Save to"** to select **"Equipment"**.
4. Press **"Equipment"** to select **"NO.1"** save position.
5. Press **"Save"** to save the current setups in equipment NO.1.

Prompt **"Data is saved successfully"** after storage is ended.

■ **Recall the setups from the equipment:**

1. Press **[SAVE/RECALL]** to skip to the **"SAVE/RECALL"** display menu.
2. Press **"Type"** to select **"Setup save"**.
3. Press **"Save to"** to select **"Equipment"**.
4. Press **"Equipment"** to select **"NO.1"** save position.
5. Press **"Recall"** to recall the setup data from the save position.

"Data is read successfully": The setups are successfully recalled and executed; **"Blank**

save unit": The current save position has no setup data.

■ Save the setups in a USB flash disc:

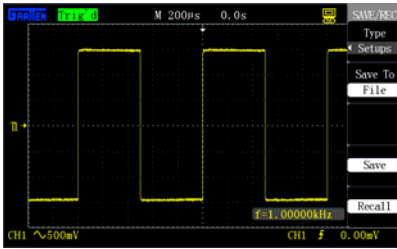

Figure 2-59 Save setups in USB flash disc



Figure 2-60 Recall setups from USB flash disc

Save the setups in a USB flash disc:

1. Press [SAVE/RECALL] and select the "Setup save" type, as shown in figure 2-59.
2. Plug the USB flash disc, and prompt "USB save equipment is connected successfully" after the connection is normal.
3. Press "Save to" to select "USB flash disc".
4. Press the "Save" option to save the setups.

The data is saved in root directory of the USB flash disc, and the file name is defaulted as GASxxxx.SET, such as GAS0001.SET.

Recall the setups from the USB flash disc:

1. Press [SAVE/RECALL], and select the "Setup save" type, as shown in figure 2-60.
2. Plug the USB flash disc, and prompt "USB save equipment is connected successfully" after the connection is normal.
3. Press "Save to" to select "USB flash disc".
4. Press "Recall" to skip to a USB flash disc file interface, as shown in figure 2-60.
5. Use the [UNIVERSAL] knob to select the recalled file.
6. Press "Recall" to recall the setup data from the save position.

"Data is read successfully": The setups are successfully recalled and executed; "Blank save unit": File is corrupted.

Press "Back" to the waveform display interface if the current USB flash disc has no setup files.

■ The save/recall waveform acquisition step is the same as the save/recall setup.

The oscilloscope enters "STOP" state after the saved waveform is recalled and displayed.

■ Image save

As shown in figure 2-61, waveform images can be saved in the USB flash disc but cannot be recalled by the oscilloscope. The images are in standard BMP format and can be opened by related software in computer.

The images are saved in the root directory of the USB flash disc, and the file name is defaulted as ASxxxx.BMP, such as GAS0001. BMP.

Table 2-41 Image save function menu:

Option	Setup	Description
Type	Image save	Save screen image
Print button	Save image	Set the [PRINT] shortcut key as save function; press the [PRINT] key to save the screen image in the USB flash disc.
Save		Save the screen image in the USB flash disc.

Save difference of two kinds of images:

[PRINT] print button: It is a shortcut key and can immediately save the screen image in any menu. See the screen capture in application example 3-7.

"Save": It can be used for saving the screen image in a special menu (see the menu bar shown in figure 2-61).

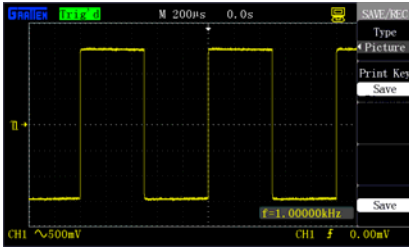

Figure 2-61 Image save

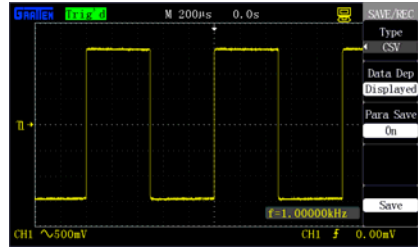

Figure 2-62 CSV save

■ CSV save

Table 2-42 CSV save function menu:

Option	Setup	Description
Type	CSV	Save CSV file in a USB flash disc.
Data length	Screen	The CSV file is used for saving the waveform data displayed on the screen.
	Internal memory	The CSV file is used for saving the waveform data of the internal memory.
Parameter save	Run	Set whether to save the corresponding parameters when saving the CSV file.
	Stop	
Save		Save the interface.

As shown in figure 2-62, the following steps can be carried out to save the CSV file in the USB flash disc:

1. Press **[SAVE/RECALL]** to skip to the **"SAVE/RECALL"** menu.
2. Press **"Type"** to select **"CSV"**.
3. Plug the USB flash disc, and prompt **"USB save equipment is connected successfully"** after the connection is normal.
4. Press **"Data length"** to select **"Screen"** or **"Internal memory"**.
5. Press **"Parameter save"** to select **"Stop"** or **"Run"**.
6. Press the **"Save"** option to save the CSV.

The data is saved in the root directory of the USB flash disc, and the file name is defaulted as GASxxxx.CSV, such as GAS0001.CSV.

The CSV file can be opened by EXCEL software in a computer.



■ **Restore the factory setups:**

When the save type is set as factory setup, press the **"Recall"** key to restore the factory setups. The shortcut key is **[DEFAULT SETUP]**.

2.12 Auxiliary system

[UTILITY] is an auxiliary system function key.

Table 2-43 Page 1 of auxiliary system function menu:

Option	Setup	Description
System state		Display the system state of the oscilloscope.
Sound		Run the key sound of the oscilloscope.
		Stop the key sound of the oscilloscope.
Frequency meter	Run	Run the frequency meter function.
	Stop	Stop the frequency meter function.
Language	Simplified Chinese	Simplified Chinese
	English	English
Next	Page 1/4	Press the option key to skip to page 2 of the menu.

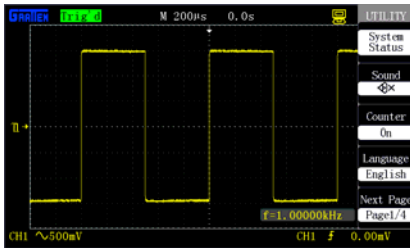

Figure 2-63 Page 1 of auxiliary function menu

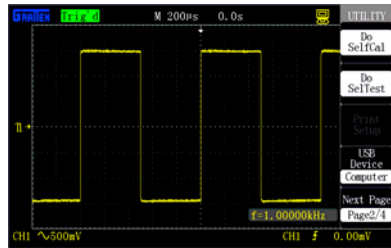

Figure 2-64 Page 2 of auxiliary function menu

Table 2-44 Page 2 of the auxiliary system function menu:

Option	Setup	Description
Self correction		Carry out self correction operation for channel correction.
Self test	Screen test	Run a screen test program.
	Keyboard test	Run a keyboard test program.
	Lightening test	Run a lightening test program.

Back USB interface	Computer	Connect the oscilloscope with the computer by a USB wire, and select "Computer" when running the principle computer GAScope1.0 software to implement remote control, and display a computer icon in the upper part of the screen at the moment.
Next	Page 2/4	Press the key to skip to page 3 of the menu.

Table 2-45 Page 3 of the auxiliary system function menu:

Option	Setup	Description
Upgrade firmware		Upgrade the software by the USB flash disc. The upgrading needs about 5 minutes.
Pass/Fail		Press the key to skip to the Pass/Fail menu.
Waveform recording		Press the key to skip to the waveform recording menu.
Interface setup		Skip to an interface setup menu.
Next	Page 3/4	Press the option key to skip to the next page of the menu.

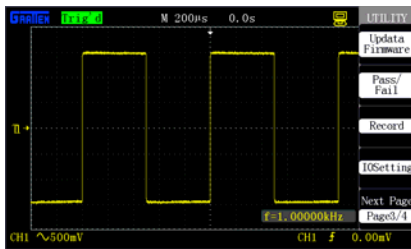

Figure 2-65 Page 3 of the auxiliary menu

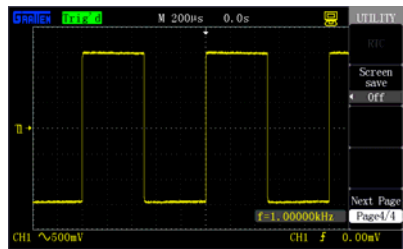

Figure 2-66 Page 4 of the auxiliary menu

Table 2-46 Page 4 of the auxiliary system function menu:

Option	Setup	Description
Screen saving	1min	Set the screen saving time.
	2min	
	5min	
	10min	
	15min	
	20min	
	1hour	
	2hour	
	5hour	
	Stop	
Next	Page 4/4	Press the option key to skip to page 1.

2.12.1 System state

Select "System state" in the [UTILITY] menu to display the system state. As shown in figure 2-67, the system state includes software and hardware versions, local model number and sequence number.

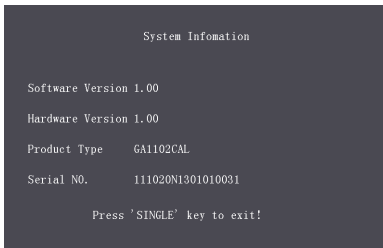

Figure 2-67 System state

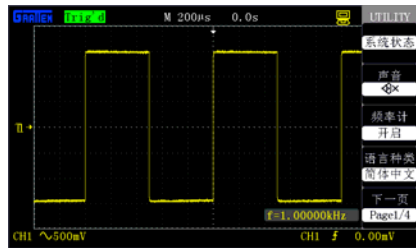

Figure 2-68 Language selection (English)

2.12.2 Language selection

This series of oscilloscope is provided with a plurality of languages that can be selected by users.

To select a display language, press [UTILITY], press "Language type" in page 1 of the "UTILITY" menu, and switch the language menu for display. Figure 2-68 shows an English menu.

2.12.3 Self correction

A self correction program can ensure a maximal measurement precision of the oscilloscope. The program can be run at any time, especially when the environment temperature is changed by more than 5 DEG C or after the program is continuously run for 30min.

For self correction, please disconnect all the probes or wires from the input connector, then press [UTILITY], press " Self correction" in page 2 of the "UTILITY" menu, and run the self correction program according to a screen prompt.

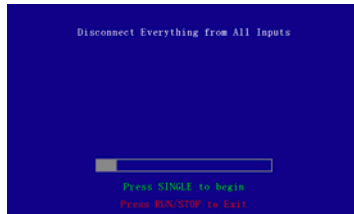

Figure 2-69 Self correction

2.12.4 Self test

Press [UTILITY], and press "Self test" in page 2 of the "UTILITY" menu. The self test includes screen test, keyboard test and lightning test.

Operation steps:

1. Screen test:

Select "Screen test" to skip to a screen test interface, as shown in figure 2-70. At the moment, the screen displays a prompt message of "Press SINGLE key to continue, Press RUN/STOP key to exit", namely start the test when prompting to press [SINGLE]. Different colors are displayed on the screen. Observe whether the screen has serious color cast or other display errors.



Figure 2-70 Screen test

2. Keyboard test

Select "Keyboard test" to skip to a keyboard test interface, as shown in figure 2-71. A rectangular region in the interface represents the key at the corresponding position on the panel; a lathy rectangle represents the knob at the corresponding position of the panel; and a square represents the press-down function of the corresponding knob. Test all the keys and knobs, and observe whether the keys and knobs respond correctly.

- The corresponding region of the screen will be in white during operation.
- Tested keys are in green, and the knob region is in red, such as "-16" in the figure, counterclockwise rotation represents "-", clockwise rotation represents "+", and the number represents number of revolution.
- A prompt message of " Press RUN/STOP key three times to exit" is displayed at the bottom of the screen to remind the user to exit the test method.

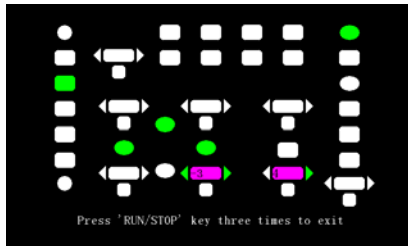

Figure 2-71 Keyboard test

3. Lightening test

Select "Lightening test" to skip to a lightening test interface, as shown in figure 2-72. At the moment, the screen displays a prompt message of "Press SINGLE key to

continue, Press RUN/STOP key to exit". After continuously pressing the [SINGLE] key, the corresponding region on the screen will be in green when the key is lightened. RUN and STOP share one key, so the key is in green at RUN state and in red at STOP state.

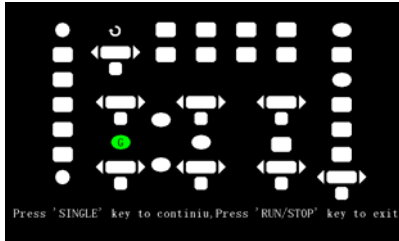

Figure 2-72 Lightening test

2.12.5 Upgrading of firmware

This series of oscilloscope can upgrade the software by the USB flash disc, which needs about 5 minutes.

The firmware is upgraded by the following steps:

1. Plug the USB flash disc in which a firmware program is saved in USB Host interface on the front panel of the oscilloscope.
2. Press [UTILITY] to skip to the "UTILITY" menu.
3. Press the "Next" option key to skip to page 3 of the auxiliary menu.
4. Press "Upgrade firmware".
5. Press [SINGLE] to execute upgrading according to the screen prompt.

Reboot the machine after finishing upgrading, and the software version is upgraded.

The oscilloscope should be self-corrected once after upgrading.

- Upgrading should be performed again by rebooting the machine if power is off or upgrading is failed during upgrading.

2.12.6 Pass/fail

"Pass/fail" is used for judging whether the input signal is in a built rule range and

outputting the past or failed waveform so as to detect the change condition of the signal.

Table 2-47 Page 1 of the pass/fail function menu:

Option	Setup	Description
Test allowed	Run	Run the pass/fail function.
	Stop	Stop the pass/fail function.
Signal source selection	CH1	Select the signal input channel.
	CH2	
Operation	▶	Run pass/fail
	■	Stop pass/fail
Display information		Open waveform pass/fail time display information.
		Close waveform pass/fail time display information.
Next		Skip to page 2 to the pass/fail menu.

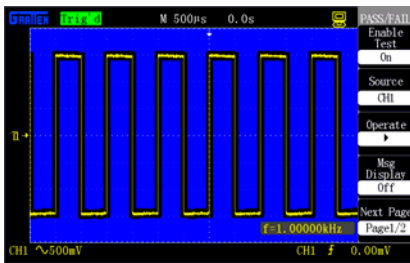

Figure 2-73 Page 1 of pass/fail menu

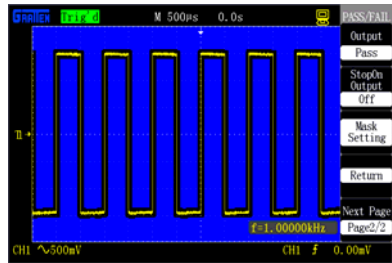

Figure 2-74 Page 2 of pass/fail menu

Table 2-48 Page 2 of the pass/fail function menu:

Option	Setup	Description
Output	Pass	Output a negative pulse train when the test is passed.
	Fail	Output a negative pulse train when the test is failed..
Output stop	Run	Enter STOP state if output exist.
	Stop	Continue to run if output exists.

Rule setup		Skip to a rule setup menu.
Back		Back to the pass/fail main menu.
Back	Page 2/2	Back to page 1 of the pass/fail menu.

Table 2-49 Page 1 of the rule setup menu:

Option	Setup	Description
Horizontal regulation		Use the [UNIVERSAL] knob to set a horizontal tolerance range: 0.04div-4.00div
Vertical regulation		Use the [UNIVERSAL] knob to set a vertical tolerance range: 0.04div-4.00div
Build rules		Build a rule template according to the two setups above.
Save position	Inside Outside	Select a save position for the rule.
Next	Page 1/2	Skip to page 2 of the rule setup menu.

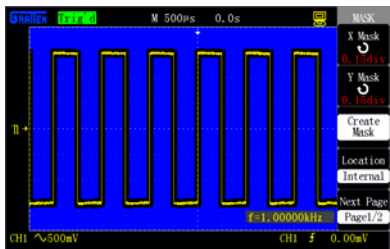

Figure 2-75 Page 1 of rule setup menu

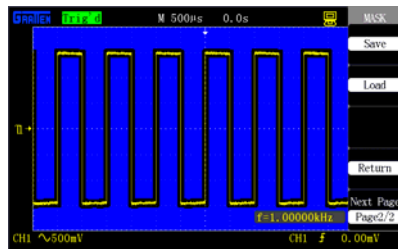

Figure 2-76 Page 2 of rule setup menu

Table 2-50 Rule setup menu 2:

Option	Setup	Description
Save		Save the rule setups.
Recall		Recall the waved rule setups.
Back		Back to the rule setup main menu.
Back	Page 2/2	Back to page 1 of the rule setup menu.

Pass/fail is carried out by the following steps:

- 1) Press **[UTILITY]** to skip to the **"UTILITY"** menu.
- 2) Continuously press **"Next"** to skip to page 3 of the auxiliary menu.
- 3) Press **"Pass/fail"** to skip to the **"PASS/FAIL"** menu.
- 4) Press **"Test allowed"** to select **"Run"**.
- 5) Press **"Signal source selection"** to select the signal input channel. In figure 2-73 CH2 is selected.
- 6) Press **"Next Page1/2"** to skip to page 2 of the pass/fail menu.
- 7) Press **"Rule setup"** to skip to page 2 of the rule setup menu, as shown in figure 2-75.
- 8) Press **"Horizontal regulation"** and **"Vertical regulation"**, and use the **[UNIVERSAL]** knob to regulate the horizontal tolerance range and the vertical tolerance range.
- 9) Press **"Build rule"** to build a rule template, or press the **"Recall"** key in the next page of the menu to recall the saved rules.
- 10) Get back to skip to page 2 of the pass/fail menu, and set the **"Output"** option as pass.
- 11) Get back to page 1 of the pass/fail menu, and press **"Operation"** ► to start.

As shown in figure 2-77, after the rules are built completely, PASS starts counting if the signal of CH2 satisfies the rules during start, and Pass would stop counting while Fail would start counting when the signal surpasses the set template (the amplitude of the signal in the figure is smaller).

Pass/Fail output

The pass/fail function can be used for outputting a negative pulse train through a Pass/Fail BNC interface on a rear panel of the oscilloscope.

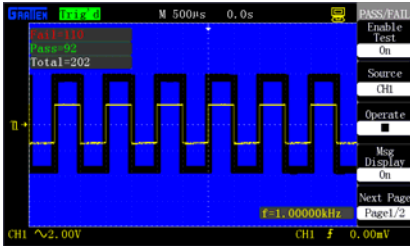

Figure 2-77 Pass/Fail Test result

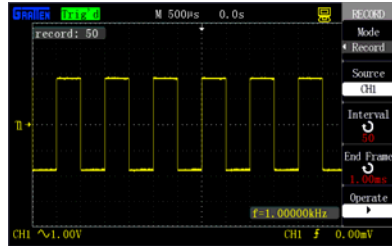

Figure 2-78 Waveform recording

2.12.7 Waveform recording

The waveform recording function can be used for recording waveforms input by channel 1 and channel 2. The user can set the time interval of the frames within 1ms-999s. At most 1000 frames of waveforms can be recorded. The waveforms can be replayed after being recorded.

Waveform recording: Record the waveforms at a specified time interval until reaching the set end frame number.

Table 2-51 Waveform recording function menu:

Option	Setup	Description
Mode	Run	Set a recording function menu.
	Stop	Set a replay function menu.
Signal source	Record	Set a recording signal source.
	Replay	
End frame	CH1	Set the maximal frame number for waveform recording.
	CH2	
Time interval		Set the time interval for waveform recording.
Operation	▶	Start to record the waveform.
	■	Stop recording the waveform.





As shown in figure 2-78, the operation steps of waveform recording are as follows:

1. Press **[UTILITY]** to skip to the **[UTILITY]** menu.
2. Press **"Next"** to skip to page 3 of the auxiliary menu.
3. Press **"Waveform recording"** to skip to the **"RECORD"** menu.

4. Press the **"Mode"** key to select **"Record"**.
5. Press the **"Signal source"** key to select the signal channel to be recorded.
6. Select the "Time interval" option, and use the [UNIVERSAL] knob to regulate the time interval of frame to frame in waveform recording.
7. Select the **"End frame"** option, and use the [UNIVERSAL] knob to regulate the maximal frame number in the waveform recording.
8. Press the **"Operation"** option  to record the waveform.

Recording replay: Replay the current recorded waveforms.

Table 2-52 Page 1 of the waveform replay function menu:

Option	Setup	Description
Mode	Replay	Set a replay function menu.
Operation		Start to replay the waveform.
		Stop replaying the waveform.
Replay mode		Circularly replay the recorded waveform.
		Replay the recorded waveform in single run.
Time interval		Set the time interval of the replayed frame to frame.
Next	Page 1/2	Skip to page 2 of the replay function menu.

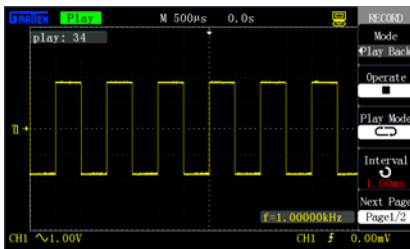

Figure 2-79 Page 1 of waveform replay menu

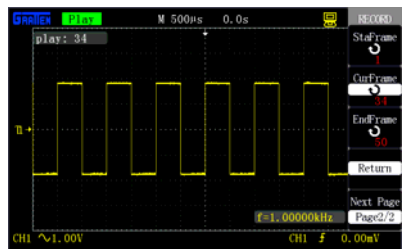

Figure 2-80 Page 2 of waveform replay menu



Table 2-53 Page 2 of the waveform replay function menu:

Option	Setup	Description
Start frame		Set a start replay frame.
Current frame		Display the current frame on the screen.

End frame		Set the replayed end frame number.
Back		Back to the main waveform recording menu.
Back	Page 2/2	Back to page 1 of the replay function menu.

During replay, the current frame number is displayed on the screen; after replay is stopped, the [UNIVERSAL] knob is used to observe all frames of waveforms between the start frame and the end frame.

The current recorded waveforms can be replayed by carrying out the following steps:

1. Press [UTILITY] to skip to the [UTILITY] menu.
2. Select "Mode" as "Replay".
3. Select "Replay mode" as  r .
4. Press "Time interval" to set the time interval of the replayed waveform frame to frame.
5. Press "Next Page1/2" to skip to page 2 of the replay function menu.
6. Press "Start frame", and revolve the [UNIVERSAL] knob to regulate the start frame number of the replayed waveforms.
7. Press "End frame", and use the [UNIVERSAL] knob to regulate the end frame number of the replayed waveforms.
8. Press the "Back Page 2/ 2" option key to get back to page 1 of the waveform replay function menu.
9. Press the "Operation" option  to replay the waveform.

2.12.8 Interface setup

The interface setup is used for setting RS-232 Baud rate, and the Baud rate can be set as 300, 2400, 4800, 9600, 19200 or 38400.

2.13 Help function

This series of oscilloscope has one-line help function that provides various language help information, and the help information can be recalled at any time as needed during use.

[HELP] is a help function key, and the user can enter or exit the help state by pressing the key. The user can recall the corresponding help information by pressing the keys when entering the help state.

The submenus in each main menu have the corresponding help information. Attention: in order to check the help information of the options in the next page of the submenu, please exit the help state at first, switch to the next page of the menu, then enter the help state again, and then press the option key to check the corresponding help information. Figure 2-81 shows the help information of **[CH1]**.

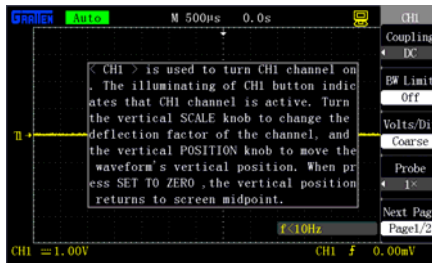

Figure 2-81 Help interface

Application examples

DIGITAL STORAGE OSCILLOSCOPE

This chapter mainly introduces several application examples, and these simplified examples importantly illustrate the main functions of the oscilloscope for your reference so as to solve your actual test problems.

- Simple measurement
- Cursor measurement
- Single signal catching
- Detailed information of analysis signal
- Application of X-Y function
- Application of arithmetical operation function in communication signal analysis
- Screen capture

3.1 Simple measurement

Observe an unknown signal in the circuit, and quickly measure and display the frequency and peak-to-peak value of the signal.

1. Use auto setup

Carry out the following steps to display the signal quickly:

- (1) Set the attenuation coefficient as 10X in the probe option by **[CH1]**, and set the switch on the probe as $\times 10$.
- (2) Connect the probe of channel 1 to a measured point of the circuit.
- (3) Carry out auto setup according to **[AUTO]**.

The oscilloscope will automatically set vertical control, horizontal control and trigger control. For better observing the waveform, you can manually regulate the control on this basis until the control satisfies your requirement.

2. Carry out automatic measurement

The oscilloscope can be used for automatically measuring most of the display signals, and the frequency and peak-to-peak values of the signal are measured according to the following steps:

(1) Measure the frequency of the signal

- Display the "MEASURE" menu according to **[MEASURE]**.
- Enter the measure type by pressing any option keys.
- Select "TIME MEASURE" and enter "TIME MEASURE" menu.

The oscilloscope displays the corresponding automatic measurement result in a waveform region of a display screen according to a detected signal.

- Select a signal input channel according to "SIGNAL SOURCE".
- Select "FREQUENCY" according to "measure type".

The corresponding icons and measurement values will be displayed in the third option.

(2) Measure peak-to-peak value of the signal

- Press the "MEASURE" key to display the "MEASURE" menu.
- Press any option key to enter the measure type.
- Select the "VOLTAGE MEASURE" option key to enter the

"VOLTAGE MEASURE" menu.

- Select the signal input channel according to the **"SIGNAL SOURCE"**.
- Select the **"peak-to-peak value"** according to the **"MEASURE TYPE"**.

The corresponding icons and measured values will be displayed in the third option.

- Display of the measurement results on the screen is changed with the change of the measured signal.
- Please regulate [Volt/div] or [s/div] if the reading of the "value" is displayed as ****.

3.2 Cursor measurement

The cursor can be used for quickly measuring the time and voltage of the waveform.

3.2.1 Measurement of the width of spike pulse

Carry out the following steps to measure the width of a spike pulse of a certain signal:

1. Press **[CURSORS]** to display the "CURSOR" menu.
2. Select "CURSOR MODE" as "MANUAL".
3. Press the option "TYPE" key, and select "TIME".
4. Press the "SIGNAL SOURCE" option key, and select **[CH1]**.
5. Press the "CurA" option key, and revolve the **[UNIVERSAL]** knob to place the cursor A at an edge of the spike pulse.
6. Press the "CurB" option key, and revolve the **[UNIVERSAL]** knob to place the cursor B at an edge that is clearest to the spike pulse.

As shown in figure 3-1, time increment Delta T and frequency increment $1/\Delta T$ (measured the width of spike pulse) will be displayed in the left upper corner of the display screen.

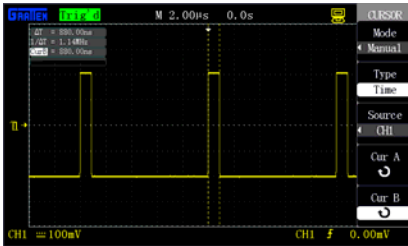

Figure 3-1 Width measurement of spike pulse

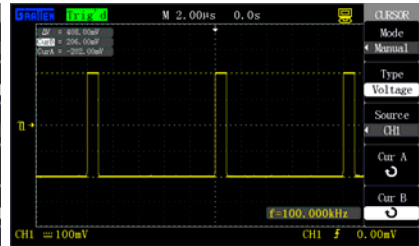

Figure 3-2 Amplitude measurement of spike pulse

3.2.2 Amplitude measurement of spike pulse

Carry out the following steps to measure the amplitude of the spike pulse:

1. Press **[CURSORS]** to display "CURSOR".
2. Select "CURSOR MODE" as "MAUNAL".
3. Press the "TYPE" option key, and select "TIME".
4. Press the "SIGNAL SOURCE" option key, and select **[CH1]**.

5. Press the **"CurA"** option key, and revolve the **[UNIVERSAL]** knob to place the cursor A at the highest wave peak of the spike pulse.
6. Press the **"CurB"** option key, and revolve the **[UNIVERSAL]** knob to place the cursor B at the lowest point of the spike pulse.

As shown in figure 3-2, the following measurement results will be displayed on the display screen:

- Voltage increment (peak-to-peak value of the spike pulse) ΔV
- Voltage at cursor A
- Voltage at cursor B

3.3 Catch the single signal

For catching a single signal, you need to understand the signal to a certain extent at first, otherwise, observe the signal at first at an automatic trigger mode or at a normal trigger mode so as to determine a suitable trigger electric level and a trigger edge.

The operation steps are as follows:

1. Set the attenuation coefficient as 10× in the probe option, and set the switch on the probe as × 10.
2. Carry out trigger setup.
 - (1) Press **[TRIG MENU]** to display the "TRIGGER" menu.
 - (2) Respectively set the type as "EDGE TRIGGER", set the signal source as **[CH1]**, set the slope as "RISE EDGE"; set the trigger mode as "ONCE", and set the coupling as "DIRECT CURRENT".
 - (3) Regulate the horizontal time base and the vertical gear to a suitable range.
 - (4) Revolve **[LEVEL]** to regulate a suitable trigger electric level.
 - (5) Press **[RUN/STOP]** to wait appearance of a signal satisfying the trigger condition, acquire the signal once and display the signal on the screen.

By this function, occasional events can be easily caught, such as sudden burrs with large amplitude; the trigger electric level is set to be an electric level that is a little larger than a normal signal; the key **[RUN/STOP]** is pressed to wait, and the machine automatically carries out triggering and records the waveform within a period before and after triggering when burrs appear. The **[POSITION]** panel is revolved to observe the waveform before appearance of the burrs.

3.4 Detailed information analysis of the signal

The detailed information of a noise signal is to be known when the noise signal is displayed on the oscilloscope, and the signal may contain much information that cannot be observed on the display screen.

3.4.1 Observe the noise signal

When the signal is displayed as a noise, the noise is suspected to cause a problem of the circuit, and the following steps can be carried out for analyzing the noise better:

1. Press **[ACQUIRE]** to display the "ACQUIRE" menu.
2. Press the "ACQUIRE MODE" key or revolve the **[UNIVERSAL]** knob to select "PEAK VALUE DETECTION".

3.4.2 Separate the signal from the noise

Carry out the following steps to reduce random noise in the display screen:

1. Press **[ACQUIRE]** to display the "ACQUIRE" menu.
2. Press the "ACQUIRE MODE" option key or revolve the **[UNIVERSAL]** knob to select "AVERAGE VALUE".
3. Press the "AVERAGE TIME " option key to check the influence caused to the waveform by changing the frequency of operating average operation, wherein the average operation can reduce the random noise and make the detailed information of the signal be easily checked.

3.5 X-Y Function application

The phase change of the measured signal is displayed as XY after the signal passes through a certain electric network, and the following steps are carried out:

1. Press **[CH1]** to set the probe option as 10×.
2. Press **[CH2]** to set the probe option attenuation as 10×.
3. Set the switches on both probes as ×10.
4. Connect the probe of channel 1 to an input point of the network, and connect the probe of channel 2 to an output point of the network.
5. Press **[AUTO]**.
6. Revolve **[Volt/div]** to make that the signal amplitudes displayed on the two channels are roughly the same.
7. Press **[DISPLAY]**, and select "XY" in a format option.

A Lissajous pattern is displayed on the screen to represent input and output characteristics of the circuit.

8. Revolve **[Volt/div]** and the vertical **[POSITION]** so as to optimize the display.
9. Observe and calculate the phase difference by an elliptical oscillography graphical method. (Shown in the figure below)

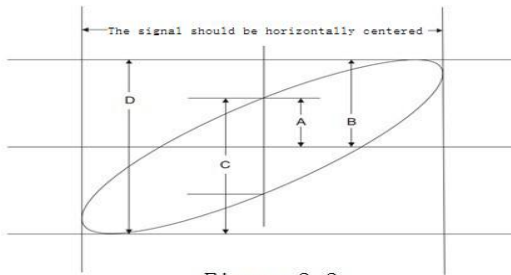

Figure 3-3

The phase difference angle θ is equal to $\pm \arcsin(A/B)$ or θ is equal to $\pm \arcsin(C/D)$ according to the formula $\sin \theta = A/B$ or C/D , wherein θ represents the phase difference angle between the channels, and A, B, C and D are defined in the figure above.

The two signals have the same amplitude if the frequency or phase difference of the two measured signals is integer multiples of $\pi/4$. The Lissajous pattern of the special signals is shown in figure 3-4, wherein $m:n$ is a frequency ratio, K represents a phase difference coefficient, and $\theta = K \times \pi/4$. Figure 2-49 is a measured Lissajous pattern when the two signals have the same frequency and amplitude and the phase difference is $\pi/2$.

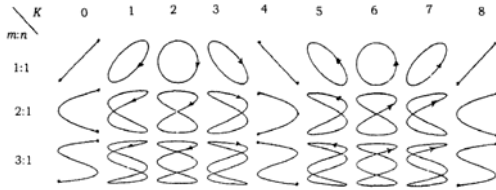

Figure 3-4 Special Lissajous pattern

3.6 Application of arithmetical operation in communication signal analysis

Interruption of a certain serial data communication link may be caused by poor signal quality. An oscilloscope is set to display the transient state of serial data stream so as to check the electric level and the jump time of the signal.

It is a difference signal, and the waveform can be displayed better by using the arithmetical function of the oscilloscope.

The following steps can be carried out by activating the difference signal connected to channel 1 and channel 2:

1. Press **[CH1]** to set the attenuation of the **"PROBE"** option as 10 \times .
2. Press **[CH2]** to set the attenuation of the **"PROBE"** option as 10 \times .
3. Set the switch on the probe as $\times 10$.
4. Press **[AUTO]**.
5. Press **[MATH]** to display the **"MATH"** menu.
6. Set **"OPERATION"** as **"—"**.
7. Select **"CH1-CH2"**, and represent the difference of the waveforms of channel 1 and channel 2 by the arithmetical operation results.
8. Press the fourth and fifth function options to regulate the vertical scale and position of the arithmetical operation waveform.

- Two probes should be compensated at first, and the differences of the probe compensation may cause errors of the measurement results.

3.7 Screen capture

Use the shortcut key [PRINT] to store the screen print in a USB flash disc.

1. Press [SAVE/RECALL] to select "IMAGE STORE".
2. Select "PRINT BUTTON" as "STORED IMAGE". Set the [PRINT] shortcut key as screen capture USB flash disc storage function.
3. Access a signal to channel 1, and press [CH1] to select "COUPLING MODE" as "ALTERNATING CURRENT".
4. Regulate the vertical gear [Volt/div] and the time base gear [s/div] to display the best waveform.
5. Plug the USB flash disc, and notice that "USB MEMORY IS CONNECTED SUCCESSFULLY" if the connection is normal.
6. Press [PRINT] to carry out storage, and notice that "DATA IS STORED SUCCESSFULLY".
7. Check the stored pictures in the computer, such as GAS0001.BMP.

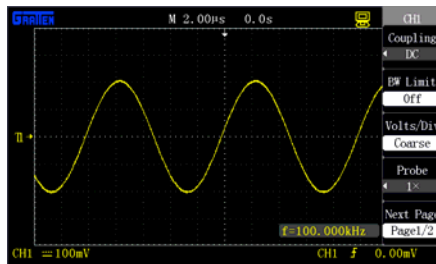

Figure 3-5 GAS0001.BMP

System prompt and fault recovery

DIGITAL STORAGE OSCILLOSCOPE

This chapter mainly introduces the problems about system prompt and fault recovery.

4

4.1 System prompt information description

- **Trigger electric level reaches the limit:** It prompts that the current trigger electric level has already reached the limit and cannot be regulated any more.
- **Horizontal position reaches the limit:** It prompts that the horizontal movement position has already reached the limit and cannot be regulated any more.
- **Voltage gear reaches the limit:** It prompts that the vertical voltage gear has already reached the lowest gear 2mV/div or the highest gear 5mV/div and cannot be regulated any more.
- **Voltage displacement reaches the limit:** The system will pop up this prompt message if channel offset is regulated to be too high or too low by revolving the knob [VERTICAL POSITION].
- **Time base gear reaches the limit:** The system will prompt this message if the horizontal time base is still regulated after being regulated to the fastest or slowest gear.
- **Hold-off time reaches the limit:** The system will prompt this message when the hold-off time is regulated to a smallest or largest value by revolving the knob [UNIVERSAL].
- **Function unavailable:** The system cannot set some functions at some special modes.
- **No signal:** This message is prompted when the signal does not satisfy the automatic setup condition during automatic setup.
- **Setup reaches the limit:** Regulation cannot be continued if the pulse width reaches the minimal value 20.0ns or the maximal value 10.0s when the knob [UNIVERSAL] is used to regulate the pulse width.
- **Blank storage unit:** This message appears when the option key [CALLOUT] is pressed if no waveform or setup is stored at the storage position in waveform storage or setup storage.
- **USB storage device is connected successfully:** This message will appear when the USB flash disc is plugged in a USB Host interface of the oscilloscope.
- **USB storage device is disconnected:** This message will appear when the USB flash disc is unplugged.

- **Data is stored successfully:** It means that the setup data, waveform data and image data are already stored in the oscilloscope or the USB flash disc.
- **Data is read successfully:** It means that the setup data or the waveform data is successfully called out from the oscilloscope or the USB flash disc.
- **USB storage device is unconnected:** This message will be prompted if the USB flash disc is not plugged for storage when the option "**store to**" is set as "**USB flash disc**" or the option "**PRINT BUTTON**" is set as "stored image" in the menu "**SAVE/RECALL**".
- **Waveform recording is finished:** The system will prompt this message when waveform recording is ended.

4.2 Fault treatment

1. If the screen of the oscilloscope is still black and does not have any display after the power switch is pressed, please follow the steps below :
 - (1) Check whether the power plug is rightly connected.
 - (2) Check whether the power switch is really pressed down.
 - (3) Reboot the instrument after finishing the inspection above.
 - (4) Please contact Gratten if the product still cannot be used properly.
2. Treat the fault according to the following steps if the waveform of the signal does not appear in the picture after the signal is acquired:
 - (1) Check whether the probe is normally connected to the signal connecting wire.
 - (2) Check whether the signal connecting wire is normally connected to the BNC.
 - (3) Check whether the probe is normally connected with a to-be-measured signal.
 - (4) Check whether a signal is generated at a to-be-measured signal point.
 - (5) Reacquire the signal once.
3. Check whether the channel attenuation coefficient accords with the probe attenuation ratio actually used if the measured voltage amplitude is 10 times larger or 10 times smaller than the actual value.
4. If waveform exists but not stable:
 - (1) Check whether the signal source option of the trigger panel accords with the signal channel actually used.
 - (2) Check the trigger type: general signals apply "EDGE TRIGGER" mode, video signals apply "VIDEO TRIGGER" mode, and the waveform is only stably displayed when suitable trigger mode is applied.
 - (3) Try to change "COUPLING" into "HIGH-FREQUENCY RESTRIT" and "LOW-FREQUENCY RESTRIT" for display so as to filter high-frequency noise or low-frequency noise triggered by interference.
5. If no waveform display during work.

Please check whether the trigger mode of the trigger panel is at the "NORMAL" or "SINGLE" position and whether the trigger electric level surpasses the waveform range, if so, center the trigger electric level, or set the trigger mode as "AUTO"

position, or automatically finish the setups above by **[AUTO]**.

6. If the display speed is lower after starting the average sampling mode or setting a long afterglow time.

It is normal.

7. If waveform display is ladder-like:

- (1) This appearance is normal.
- (2) The horizontal time base gear may be too low, and the display can be improved by increasing the horizontal time base to increase the horizontal resolution.
- (3) The display type may be "VECTOR", and the linked line between the sampling points may cause ladder-like display of the waveform. This problem can be solved by setup the display type as "POINT" display mode.

Service and Support

DIGITAL STORAGE OSCILLOSCOPE

This chapter mainly introduces the related information of the service and support of the oscilloscope product.

5.1 Maintain summary

Gratten warrants that the products that it manufactures and sells will have no material and technical defects within two years (accessories within one year) since the delivery date of the authorized distributor. If the products indeed have defects within the guarantee time, Gratten will provide repair or replace services according to detailed provision on the warranty bill.

Please contact the nearest sales and service agency of Gratten if needing services or requesting a complete copy of the warranty bill.

Except the warranties in the summary or provided in an applicable warranty bill, Gratten makes no warranty of any kind, express or implied, including without limitation the implied warranties according to merchantability and particular applicability. Gratten assumes no responsibility for any indirect and special damage inflicted on purpose.

Appendix

DIGITAL STORAGE OSCILLOSCOPE

This chapter introduces the technical specifications and default settings of the GA1000 series of oscilloscope.

6

Appendix A: Technical specifications

All technical specifications are applicable to probes of which the attenuation switches are set as $\times 10$ and this series of digital oscilloscope. To check whether the oscilloscope satisfies the technical specifications, the oscilloscope should satisfy the following conditions at first:

- The oscilloscope should run for at least 30min within a specified operation temperature range.
- **"SELF CORRECTION"** should be implemented if the change range of the operation range is 5 DEG C or higher, and this operation can be carried out by the **"AUXILIARY FUNCTION"** menu.

All the specifications are ensured to satisfy the requirement except that marked with **"TYPICAL"** sign.

Technical specifications

Input	
Input coupling	AC, DC, GND
Input impedance	$1\text{M}\Omega \pm 3\% \parallel 16\text{pF} \pm 3\text{pF}$ ($50\Omega \pm 2\%$ GA1302CAL)
Maximum input voltage	400V (DC+AC peak value, $1\text{M}\Omega$ input impedance)
Probe attenuation	1X, 10X, 100X, 1000X

Signal acquisition system	
Sampling mode	Real-time sampling
Sampling rate	Single channel 2GSa/s; dual channel 1GSa/s (Only to GA1302CAL/GA1202CAL) Single channel 1GSa/s, dual channel 500MSa/s (only to GA1102CAL)
Storage depth	Single channel 40kpts Dual channel 20kpts
Acquire mode	Sampling, peak value detection, average value
Average time	4, 16, 32, 64, 128, 256

Vertical system	
Vertical sensitivity	2mV/div - 5V/div (1-2-5 step-by-step)
Channel voltage offset range	±10div offset from the screen center
Vertical resolution	8bit
Channel amount	2
Bandwidth	300MHz(only to GA1302CAL) 200MHz(only to GA1202CAL) 100MHz(only to GA1102CAL)
AC plus accuracy	2mV/div ≤±4%, the rest gears ≤±3%
DC measurement accuracy	±[DC measurement accuracy x reading+ (1% x vertical displacement reading) +0.2div]
Rise time	< 1.2ns(only to GA1302CAL) < 1.8ns(only to GA1202CAL) < 3.5ns(only to GA1102CAL)
Vertical coupling	AC,DC,GND
Arithmetical operation	+, -, ×, ÷, FFT
FFT	Window mode: Hanning, Hamming, Blackman Sampling points : 1024
Bandwidth limit	20MHz (-3dB)

Horizontal system	
Time base	2ns/div ~ 50s/div, step 32 gears according to sequence 1-2-5 (only to GA1102CAL/GA1202CAL) 1ns/div ~ 50s/div, step 33 gears according to sequence 1-2-5 (only to GA1302CAL) Wherein, 100ms/div ~ 50s/div is the scan shift.
Horizontal displacement range	100div
Display mode	Y-T mode, X-Y mode

X-Y mode phase difference	±3 Degrees
Display type	Point display, vector display

Trigger system

Trigger type	Edge, pulse, video, slope, alternation
Trigger signal source	CH1, CH2, EXT, EXT/5, AC Line
Trigger mode	Auto, normal, single
Trigger coupling	DC, AC, Low-frequency rejection, high-frequency rejection
Trigger electric level range	CH1, CH2: ±10div EXT: ±1.5V EXT/5: ±7.5V
Trigger sensitivity	CH1, CH2: ≤1div EXT: ≤0.15V EXT/5: ≤0.75V
Hold-off range	100ns ~ 10s
Edge trigger	Type: rise, descend, rise and descend edge
Pulse width trigger	Type: (>, <, =) positive pulse width (>, <, =) negative pulse width Pulse width: 20ns ~ 10s Pulse width resolution: 5ns or 1% (take the higher value)
Video trigger	Support signal system: PAL, NTSC Trigger condition: odd field, even field, all rows, specified row
Slope trigger	(>, <, =) positive slope (>, <, =) negative slope Time setup: 20ns-10s
Alternating trigger	CH1 trigger type: edge, pulse, video, slope CH2 trigger type: edge, pulse, video, slope

Measurement system

Automatic measurement (32	Maximal value, minimal value, peak-to-peak value, amplitude, top value, bottom value, periodic average
---------------------------	--

kinds)	value, average value, periodic mean square root, mean square root, rise extreme, descend extreme, rise time, descend time, frequency, period, pulse width, positive pulse width, negative pulse width, positive duty ratio, negative duty ratio, phase, FRR, FRF, FFR, FFF, LRR, LRF, LFR, LFF
Cursor measurement	Manual measurement mode, cursor tracking measurement mode

Control panel Function

Auto setup	The auto setup function can realize automatic regulation of the vertical system, the horizontal system and the trigger position.
Save/recall	2 groups of reference waveform, 20 groups of common waveform, 16 groups of setups; save and recall from USB flash drive of the waveform, setups, CSV and bitmap files (CSV and the bitmaps cannot be recalled from the USB flash disc) are supported.

Hardware frequency counter

Reading resolution ratio	6 bits
Range	Alternating-current coupling, from 10Hz to the maximal bandwidth
Signal source	All sources capable of being triggered in pulse trigger or edge trigger type

General specifications

Display system

Display type	TFT 7-inch (178mm) LCD
Display resolution ratio	800 (horizontal) pixels x 480 (vertical) pixels
Display color	64k color

Contrast ratio (typical)	500:1
Background intensity (typical)	300 Cd/m ²
Waveform display range	14 × 8 grids
Afterglow	Off, 1 second, 2 seconds, 5 seconds, infinite
Menu display	2 seconds, 5 seconds, 10 seconds, 20 seconds, infinite
Screen saver	Off, 1min, 2min, 5min, 10min, 15min, 20min, 1h, 2h, 5h
Interpolation mode	Sine interpolation, linear interpolation
Screen color mode	Normal, inverse phase
Display language	Simplified Chinese, English

Power supply

Power voltage	100-240 VAC, CAT II, auto selection
AC power supply frequency range	45Hz to 440Hz
Consumed power	50VA Max

Environment

Temperature	Operating: 10 °C to +40 °C Non operating: -20 °C to +60 °C
Cooling	Forced cooling of fan
Humidity	≤ 90% below 40 °C
Height	Operating: smaller than 3000m Non operating: smaller than 15000m



Mechanical specifications

Size	339mm×149mm×111mm (width x height x depth)
Weight	About 2.3kg

Appendix B : Default setup

Menu or system	Option, knob or key	Default setup
CH1 CH2	Coupling	Direct current
	Bandwidth limit	OFF
	Volt/div	Coarse tuning
	Probe	1×
	Inverse phase	OFF
	Volt/div	200mV
	Digital filter	OFF
MATH	Operation	CH1+CH2
	FFT operation	
	Signal source	CH1
	Window	Hanning
	Horizontal amplification	1×
HORIZONTAL	Vertical scale	dBVrms
	Window	Main time base
	Position	0.0s
	S/div	100μs
	Window region time base	5.0μs
CURSOR	Type	OFF
	Signal	CH1
	Voltage	±2 G
	Time	±2G
MEASURE	Signal source	CH1

	Type	Peak-to-peak value
		Average value
		Amplitude
		Period
		Rise time
ACQUIRE	Three mode options	sampling
	Average time	4
	Interpolation type	Sine
DISPLAY	type	vector
	Go on	OFF
	Waveform brightness	100%
	Grid brightness	100%
	Format	YT
	Menu display	Infinite
SAVE/RECALL	Type	Save setup
	Save to	Equipment
	Set	No.1
REF	Signal source	CH1
	REFA/REFB	REFA
	REFA	OFF
	REFB	OFF
UTILITY	Source	OFF
	Frequency meter	ON
	Back USB interface	Computer

	Test passed	OFF
	Waveform recording	OFF
	RS-232	Baud rate 300
TRIGGER (EDGE)	Type	Edge
	Signal source	CH1
	Slope	Rise
	Trigger mode	Auto
	Coupling	Direct current
	Electric level	0.00mV
	TRIGGER (PULSE)	Type
Signal source		CH1
Condition		
Pulse width setup		20.00ns
Trigger mode		Auto
Coupling		Direct current
TRIGGER (VIDEO)	Type	Video
	Signal source	CH1
	Polarity	
	Synchro	All rows
	Standard	NTSC
	Trigger mode	Auto
TRIGGER (SLOPE)	Type	Slope
	Signal source	CH1
	Condition	

	Time setup	20.00ns
	Trigger mode	Auto
TRIGGER (ALTERNATION)	Type	Alternation
	Signal source	CH1
	Trigger mode	Edge
	Coupling	Direct current
	Slope	Rise edge

Appendix C: Daily maintenance and cleaning

Daily maintenance:

Do not let the liquid crystal displayer be suffered from direct irradiation of sunshine when storing or placing it.

Attention: Do not place the instrument or probe in fog, liquid or solvent for avoiding damage of the instrument or probe.

Cleaning:

Usually check the instrument and the probe according to operation condition, and clean the external surface of the instrument according to the following steps:

1. Use a soft rag to wipe surface dust outside the instrument and the probe, and do not scratch the transparent plastic protective screen when cleaning the liquid crystal displayer.
2. Use a wet soft cloth to clean the instrument, and please cut off the power supply. For more complete cleaning, please use a hydro-solvent of 75% of isopropanol.

- To avoid damage of the surface of the instrument of probe, please do not use any corrosive reagent or chemical cleaning reagent.
- Before use, after the power on, please confirm that the instrument is completely dry so as to prevent short circuit or even personal injury caused by moisture.



Add: Building A8, Tanglang Industrial Zone, Xili,
Nanshan, Shenzhen, 518055, P. R. China
Tel: +86-755-6161 8252 / 6161 8291 / 2655 9660
Fax: +86-755-6161 8298
e-mail: atten8@atten.com.cn
<http://www.glarun-atten.com>